

# Audit & Risk Committee Meeting

## Notice of Meeting | 14th November 2023

Dear Councillors

I respectfully advise that the AUDIT & RISK COMMITTEE MEETING will be held in the Council Chambers, 10 Jennaberring Road, Quairading, WA on 14th November 2023 commencing at 5.00pm

MEETING AGENDA ATTACHED



**Natalie Ness**  
CHIEF EXECUTIVE OFFICER

Date: 10 November 2023

---

### Disclaimer

Members of the public should note that in any discussion regarding any planning or other application that any statement or intimation of approval made by any member or officer of the Shire of Quairading during the course of any meeting is not intended to be and is not to be taken as notice of approval from the Shire of Quairading. No action should be taken on any item discussed at a Council meeting prior to written advice on the resolution of the Council being received.

Any plans or documents contained in this document may be subject to copyright law provisions (Copyright Act 1968, as amended) and the express permission of the copyright owner(s) should be sought prior to the reproduction.

---



## CONTENTS

<b>ITEM 1</b>	<b>OPENING &amp; ANNOUNCEMENTS .....</b>	<b>4</b>
<b>ITEM 2</b>	<b>ATTENDANCE AND APOLOGIES .....</b>	<b>4</b>
<b>ITEM 3</b>	<b>DEPUTATIONS/PRESENTATIONS/SUBMISSIONS/PETITIONS .....</b>	<b>5</b>
<b>ITEM 4</b>	<b>DECLARATIONS OF INTEREST .....</b>	<b>6</b>
<b>ITEM 5</b>	<b>CONFIRMATION OF MINUTES AND BUSINESS ARISING .....</b>	<b>7</b>
5.1	Confirmation of Minutes: Audit & Risk Committee Meeting – 12 September 2023 .....	7
	BUSINESS ARISING .....	7
<b>ITEM 6</b>	<b>STANDING ITEMS – EXTERNAL AUDIT .....</b>	<b>8</b>
6.1	2022/2023 Financial Audit - Office of the Auditor General (OAG) .....	8
6.2	Audit register - progress report.....	11
<b>ITEM 7</b>	<b>STANDING ITEMS – FINANCIAL REPORTING .....</b>	<b>15</b>
7.1	Finalise Procurement, Request for Tender for two (2x) 6-wheel Tipper Trucks.....	15
<b>ITEM 8</b>	<b>STANDING ITEMS – CONTROLS, SYSTEMS AND PROCEDURES .....</b>	<b>94</b>
8.1	Information Technology (IT) Usage Policy & Procedure .....	94
8.2	Request to Increase Credit Card Limits .....	107
8.3	Response to Minister following adoption of ICT Strategic Plan 2022-2025.....	110
<b>ITEM 9</b>	<b>STANDING ITEMS – RISK MANAGEMENT REPORTS AND ISSUES .....</b>	<b>113</b>
9.1	Report on excess annual leave and long service leave entitlements .....	113
<b>ITEM 10</b>	<b>EMERGING ISSUES/LATE ITEMS .....</b>	<b>119</b>
<b>ITEM 11</b>	<b>NEXT MEETING DATE.....</b>	<b>120</b>
<b>ITEM 12</b>	<b>CLOSURE .....</b>	<b>120</b>

## **SHIRE OF QUAIRADING**

### **Audit & Risk Committee Meeting**

#### **ITEM 1      OPENING & ANNOUNCEMENTS**

The Chairperson opened the Meeting at \_\_\_\_\_ pm.

“Before we start our meeting, I would like to acknowledge that we are meeting on Noongar/Ballardong land. We pay respect to the original custodians of the land...past, present and future. I welcome you all here today for this meeting.”

#### **ITEM 2      ATTENDANCE AND APOLOGIES**

##### **Councillors**

Cr JN Haythornthwaite	Shire President
Cr TJ Stacey	Deputy Shire President
Cr FC Faltyn	
Cr JC Hayes	
Cr JR Hippisley	

##### **Council Officers**

Ms NJ Ness	Chief Executive Officer
Ms T Brown	Executive Manager, Corporate Services
Ms SE Caporn	Executive Manager, Works & Services
Ms M Haeusler	Executive Officer

##### **Observer/Visitor**

Nil

##### **Apologies**

Cr BR Cowcill  
Cr PD Smith

##### **Leave of Absence Previously Granted**

Nil

**ITEM 3      DEPUTATIONS/PRESENTATIONS/SUBMISSIONS/PETITIONS**

**ITEM 4      DECLARATIONS OF INTEREST**

Elected Members in accordance with section 5.61 and 5.65 of the Local Government Act 1995 and the *Local Government (Model Code of Conduct) Regulations 2021* Schedule 1 Division 4 regulation 22:

A member who has an interest in any matter to be discussed at a Council or Committee meeting that will be attended by the member must disclose the nature of the interest -

- a. in a written notice given to the CEO before the meeting; or
- b. at the meeting immediately before the matter is discussed.

Local Government employees in accordance with section 5.70 or 5.71 of the *Local Government Act 1995* and the *Local Government (Administration) Regulations 1996* Part 4A Division 2, regulation 19AD:

An employee who has an interest in any matter to be discussed at a council or committee meeting attended by the local government employee disclose the nature of the interest —

- a. in a written notice given to the CEO before the meeting; or
- b. at the meeting immediately before the matter is discussed.

**ITEM 5 CONFIRMATION OF MINUTES AND BUSINESS ARISING**

**5.1 Confirmation of Minutes: Audit & Risk Committee Meeting – 12 September 2023**

---

**OFFICER RECOMMENDATION**

That the Minutes of the Audit & Risk Committee Meeting held on the 12 September 2023 be confirmed as a true and accurate record.

---

**BUSINESS ARISING**

**ITEM 6      STANDING ITEMS – EXTERNAL AUDIT****6.1            2022/2023 Financial Audit - Office of the Auditor General (OAG)**

<b>Responsible Officer</b>	Natalie Ness, Chief Executive Officer
<b>Reporting Officer</b>	Tricia Brown, Executive Manager, Corporate Services
<b>Attachments</b>	Nil
<b>Voting Requirements</b>	Simple Majority
<b>Disclosure of Interest</b>	Reporting Officer: Responsible Officer:

---

**OFFICER RECOMMENDATION**

That the Audit & Risk Committee recommend to Council, that Council:

1. Receives the Audit Register, for progress to be reported quarterly through the audit register – progress report Attachment (i)
  2. Notes that the Auditors commenced the Final Audit for 2022-2023 on the 30<sup>th</sup> October 2023 to the 1<sup>st</sup> November 2023 onsite.
- 

**IN BRIEF**

- The Final onsite Audit visit was conducted by AMD on the 30<sup>th</sup> October through to 1<sup>st</sup> November 2023 with offsite work still being conducted.

**MATTER FOR CONSIDERATION**

Further requests following the onsite Audit are being conducted daily through the AMD Online document portal with 76% of items being accepted as at 05/11/2023.

**BACKGROUND**

The external audit, also known as financial audits or audit of the annual financial statements, focuses on providing an objective and independent examination of the financial statements prepared by the Shire, increasing the value and user confidence in the financial statements.

AMD Chartered Accountants (AMD) have been contracted by the OAG to perform the Shire's financial report audit for a 3-year period, commencing with the audit for the year ended 30<sup>th</sup> June 2021 (prior year audit). The audit occurs in two steps; the first being an interim audit, with the second (final) stage being the audit work to attest the balances and notes that comprise the annual financial statements.

Bob Waddell and Associates were engaged to complete the Shire's Annual Financial Statements for the year ended 30<sup>th</sup> June 2023 and is in its final review by the Auditors.



**STATUTORY ENVIRONMENT**

*Local Government Act 1995*

*Local Government (Financial Management) Regulations 1996*

*Local Government (Audit) Regulations 1996*

*Australian Accounting Standards*

*International Financial Reporting Standards*

**POLICY IMPLICATIONS**

Purchasing Policy

Delegation 1.1.13: Payments from the municipal or trust funds

Records Management Policy

Significant Accounting Policies

Delegations Register

**FINANCIAL IMPLICATIONS**

Council has a budget allocation of \$32,000 in the 2023/24 budget for the conduct of the external audit function by the Office of the Auditor General (OAG), for the audit of the 2022/23 annual financial statements. It is anticipated that a budget of similar amount is to be adopted each year but will be subject to an annual estimate of audit fees provided by the OAG. Officers' efforts to undertake the improvements and report on progress have not been estimated or reported.

**ALIGNMENT WITH STRATEGIC PRIORITIES**

- 5.3 Governance & Leadership:** Provide informed and transparent decision making that, meets our legal obligations, and the needs of our diverse community
- 5.4 Governance & Leadership:** Implement systems and processes that meet legislative and audit obligations

**CONSULTATION**

Nil.

**RISK MANAGEMENT PRIORITIES**

This report addresses the following identified Strategic Risk Management Priorities:

Financial misconduct by (a) a Shire employee, and (b) an executive/office holder results in financial, legal and/or reputational damage.

Misconduct (non-financial) by a Shire employee results in financial, legal and/or reputational damage.

**RISK ASSESSMENT**

	Option 1
Financial	<p>Low</p> <p><i>Cost of the audit is included in the budget. The audit’s purpose is not to uncover any financial fraud, however having strong financial processes, as raised in the management report can reduce the risk of this occurring.</i></p>
Health	<p>Low</p>
Reputation	<p>Low</p> <p><i>Compliant with legislative requirements. Failure to complete the annual financial audit would lead to increased reputational risk and possible actions by the OAG.</i></p>
Operations	<p>Low</p> <p><i>Council’s Management and administration staff assist AMD by providing all information and documents requested. Operational impact is minimal in reporting progress on audit findings, however the operational impact of not closing findings would be significantly higher if conditions escalated.</i></p>
Natural Environment	<p>Low</p>

	Consequence				
Likelihood	Insignificant	Minor	Moderate	Major	Critical
Rare	LOW Accept the risk Routine management	LOW Accept the risk Routine management	LOW Accept the risk Routine management	MEDIUM Specific responsibility and treatment	HIGH Quarterly senior management review
Unlikely	LOW Accept the risk Routine management	LOW Accept the risk Routine management	MEDIUM Specific responsibility and treatment	MEDIUM Specific responsibility and treatment	HIGH Quarterly senior management review
Possible	LOW Accept the risk Routine management	MEDIUM Specific responsibility and treatment	MEDIUM Specific responsibility and treatment	HIGH Quarterly senior management review	HIGH Quarterly senior management review
Likely	MEDIUM Specific responsibility and treatment	MEDIUM Specific responsibility and treatment	HIGH Quarterly senior management review	HIGH Quarterly senior management review	EXTREME Monthly senior management review
Almost certain	MEDIUM Specific responsibility and treatment	MEDIUM Specific responsibility and treatment	HIGH Quarterly senior management review	EXTREME Monthly senior management review	EXTREME Monthly senior management review

**COMMENT**

The CEO and EMCS will continue to report on progress of audit findings through the Audit Progress Register that is submitted to the Audit and Risk Committee and recommended to Council.

**6.2 Audit register - progress report**

<b>Responsible Officer</b>	Natalie Ness, Chief Executive Officer
<b>Reporting Officer</b>	Tricia Brown, Executive Manager, Corporate Services
<b>Attachments</b>	1. (i) Audit Register (confidential)
<b>Voting Requirements</b>	Simple Majority
<b>Disclosure of Interest</b>	Reporting Officer: Responsible Officer:

---

**OFFICER RECOMMENDATION**

That the Audit & Risk Committee recommends to Council that Council;

1. notes the progress recorded against each item within the audit register in confidential attachment (i); and
  2. approves the one (1) finding marked as Closed (100%) in the audit register, to be registered complete, removed from the register and no longer reported to the Committee.
- 

**IN BRIEF**

- This report provides an update on the progress of actions included in the audit register.
- The audit register includes all open audit findings that have previously been accepted by the Audit and Risk Committee.
- Reporting through the audit register commenced in November 2021 and includes items from the 2020/21 interim audit, and all subsequent audits.

**MATTER FOR CONSIDERATION**

Receipt of the audit register progress report to November 2023.

**BACKGROUND**

The external audit, also known as financial audits or audit of the annual financial statements, focuses on providing an objective and independent examination of the financial statements prepared by the Shire, increasing the value and user confidence in the financial statements.

The audit register lists findings from audit reports previously accepted by the Audit & Risk Committee. The register describes the progress of implementing improvements and percentage completion. Progress on the actions are monitored by management, this Committee and Council.

The 2023/24 (draft) annual financial report was sent to the auditor on the 30<sup>th</sup> September 2023.

Any findings from the final management letter will form part of this report.

**STATUTORY ENVIRONMENT**

*Local Government (Audit) Regulations 1996*

*Local Government (Financial Management) Regulations 1996*

*Local Government Act 1995*

**POLICY IMPLICATIONS**

Nil

**FINANCIAL IMPLICATIONS**

Council has a budget allocation of \$32,000 in the 2023/2024 Budget for the conduct of the external audit function by the Office of the Auditor General, for the audit of the 2022/23 annual financial statements. It is anticipated that a budget of a similar amount is to be adopted each year but will be the subject of an annual estimate of audit fees provided by the OAG. Officers’ efforts to undertake the improvements and report on progress has not been estimated or reported.

**ALIGNMENT WITH STRATEGIC PRIORITIES**

**5.4 Governance & Leadership:** Implement systems and processes that meet legislative and audit obligations

**CONSULTATION**

Nil.

**RISK ASSESSMENT**

	Option 1
Financial	Low <i>Cost of the annual audit is included in the budget. By regularly reviewing progress against audit findings, the risks associated to misconduct and error are significantly reduced.</i>
Health	Low
Reputation	Low <i>Compliant with legislative requirements. Failure to complete the findings from audit reports would lead to increased reputational risk.</i>
Operations	Low <i>Operational impact is minimal in reporting progress on audit findings. Operational impact of not closing findings would escalate.</i>
Natural Environment	Low

Likelihood	Consequence				
	Insignificant	Minor	Moderate	Major	Critical
Rare	LOW Accept the risk Routine management	LOW Accept the risk Routine management	LOW Accept the risk Routine management	MEDIUM Specific responsibility and treatment	HIGH Quarterly senior management review
Unlikely	LOW Accept the risk Routine management	LOW Accept the risk Routine management	MEDIUM Specific responsibility and treatment	MEDIUM Specific responsibility and treatment	HIGH Quarterly senior management review
Possible	LOW Accept the risk Routine management	MEDIUM Specific responsibility and treatment	MEDIUM Specific responsibility and treatment	HIGH Quarterly senior management review	HIGH Quarterly senior management review
Likely	MEDIUM Specific responsibility and treatment	MEDIUM Specific responsibility and treatment	HIGH Quarterly senior management review	HIGH Quarterly senior management review	EXTREME Monthly senior management review
Almost certain	MEDIUM Specific responsibility and treatment	MEDIUM Specific responsibility and treatment	HIGH Quarterly senior management review	EXTREME Monthly senior management review	EXTREME Monthly senior management review

**COMMENT**

The audit register **confidential attachment (i)** counts actions and totals by “Finding #”. Each finding may have more than one “recommendation” and associated “agreed management action”. Only when all recommendations and agreed management actions within a finding are deemed complete will the finding as a whole be totalled at 100% complete and recommended to be closed.

The process for adding and removing findings to the audit register is as follows:

1. An external audit is completed, and an audit report is finalised.
2. The audit report is presented to the Audit and Risk Committee (ARC).
3. The ARC recommends to Council that it notes and accepts the audit report.
4. All findings from the audit report are **added** to the audit register.
5. Progress is reported by management with updates recorded quarterly in “officer comment / action taken”.
6. Any findings deemed as complete by management are marked as “100% complete” with the status of “closed”.
7. The audit register – progress report is submitted by management to the ARC.
8. The ARC reviews the audit register and confirms completion of any 100% and closed findings.
9. The ARC recommends to Council that it notes progress and approves the findings marked as complete to be registered as closed.
10. Closed findings are **removed** from the audit register.

A summary of the audit register, included below, will illustrate the trend of actions that have been added, progressed, and completed.

The blue row represents actions added by the ARC. New audit findings presented to the current meeting are included at the subsequent meeting, following acceptance.

The green row represents actions closed by the ARC and will always total 0 for the current meeting date. The closed actions from the current meeting will then be shown in the “closed by the Audit & Risk Committee” total in the subsequent meeting’s table summary.

Status of Actions	ARC - Meeting Date						TOTAL
	9/2022	12/2022	3/2023	6/2023	9/2023	11/2023	
New actions added by ARC	0	6	0	0	0	0	0
Not commenced ≤10%	0	0	0	0	0	0	
Progressed >11% to 99%	0	4	3	3	4	4	
Completed =100%	2	2	1	1	0	1	
<b>Total (0% to 100%)</b>	<b>2</b>	<b>6</b>	<b>4</b>	<b>4</b>	<b>6</b>	<b>6</b>	
Closed by ARC	2	2	1	0	0	1	6
Total cumulative closed by ARC	7	9	8	8	8	9	
Open Actions	0	4	7	7	7	6	











The committee is requested to recommend to Council that Council note the progress and Officer comments.

No new actions have been added to the register following the 06/12/2022 endorsement by Council. There is one (1) finding marked as complete (100%) in the audit register to be registered as closed, the remaining six (6) are progressing.

All closed items will not form part of the audit register report for future meetings. The closed items are available for external auditors and committee/council to review.

It is requested to note the audit register progress report in **confidential attachment (i)**.

**ITEM 7      STANDING ITEMS – FINANCIAL REPORTING****7.1            Finalise Procurement, Request for Tender for two (2x) 6-wheel Tipper Trucks****Responsible Officer**    Natalie Ness, Chief Executive Officer**Reporting Officer**       Sarah Caporn, Executive Manager, Works & Services**Attachments**

1.    Request for Tender, Scope [↓](#) 
2.    Request for Tender, Coversheet [↓](#) 
3.    RFT Suppliers [↓](#) 
4.    UD Response [↓](#) 
5.    Fuso Response [↓](#) 
6.    Fuso Tipper Body Quote [↓](#) 
7.    Fuso Spec Sheet [↓](#) 
8.    Isuzu Response [↓](#) 
9.    Isuzu Spec Sheet [↓](#) 
10.   Iveco Response [↓](#) 
11.   Iveco Tipper Body Quote [↓](#) 

**Voting Requirements**   Simple Majority**Disclosure of Interest**   Reporting Officer:

Responsible Officer:

---

**OFFICER RECOMMENDATION**

1.    That the Audit & Risk Committee recommends to Council to purchase two Fuso trucks from Daimler Trucks.

---

**IN BRIEF**

The Executive Manager of Works and Services (EMWS) prepared a Request for Tender as per Attachment 1.

The document was circulated to a group of suitable suppliers via the WALGA Vendor Panel/eQuote system, closing on Thursday 12<sup>th</sup> October 2023.

EMWS along with our two Works Supervisors completed an evaluation, assessing engine power, build quality of the tipping body, capacity, warranty and price. The panel concluded that the Fuso offered the best value for money for Council.

**MATTER FOR CONSIDERATION**

Four submissions were received. The pricing is tabulated below, and full quotes are as per the attachments.

Supplier	Made & Model	Cab/Chassis Price (ex GST)	Tipper Body Price	Subtotal <i>incl full scope, accessories and on-road costs</i>	For 2 units	Trade-In (Q272 & Q5512)	Net Cost
Truck Centre WA	<b>UD Truck, CW 26 460</b> <b>(Park Bodybuilders)</b>	\$189,994	\$76,500	\$266,494	<b>\$532,988</b>	\$90,909 + \$81,818 <b>\$172,727</b>	\$360,261
Daimler Trucks	<b>Shogun Fuso FV70</b> <b>(Bruce Rock Engineering)</b>	\$190,486	\$102,257	\$292,743	<b>\$585,486</b>	\$100,000 + \$110,000 <b>\$210,000</b>	\$375,486
Major Motors	<b>Isuzu FXZJJ-L23</b> <b>(TL Engineering)</b>	\$206,400	\$89,950	\$296,350	<b>\$592,700</b>	\$105,000 + \$100,000 <b>\$205,000</b>	\$387,700
AV Truck Services	<b>Iveco S-Way</b> <b>(Park Bodybuilders)</b>	\$267,873.80	\$80,500	\$348,373	<b>\$756,746</b>	\$45,090 + \$35,090 <b>\$80,180</b>	\$676,566

**BACKGROUND**

As per the 10-Year Plant Replacement Plan, our two 6-wheel tippers are due for trading. One trade-in should have been completed in 2022/23 but was not correctly executed as a Tender under the Purchasing Policy so two units have been requested in this RFT.

**STATUTORY ENVIRONMENT**

*Local Government Act 1995*

*Local Government (Financial Management) Regulations 1996*

**POLICY IMPLICATIONS**

Purchasing Policy

**FINANCIAL IMPLICATIONS**

Council allocated \$292,702 for the purchase of each truck with an expected trade value of \$110,000. The prices have gone up slightly since our budget figures and the trade-in value is a total of \$105,000 per truck.

The proposed purchase is \$10,082 more than current budget but this was based on 2022/23 pricing.

The Fuso has an excellent reputation as a reliable vehicle with a quality tipper body made by Bruce Rock Engineering.



The EMWS will be requesting that the Hydraulic Tip Trailer (\$8,000) and the Bobcat Trencher attachment (\$8,000) be removed as part of the upcoming budget review so it is anticipated that those savings can be reallocated towards the additional plant expenditure needed here.

**ALIGNMENT WITH STRATEGIC PRIORITIES**

- 3.1 Built Environment:** Safe, efficient and well maintained road and footpath infrastructure
- 3.2 Built Environment:** Parks, gardens and social spaces are safe and encourage active, engaged and healthy lifestyles
- 3.3 Built Environment:** Improvements to building infrastructure including our sport and recreation facilities, residential and service delivery facilities following considered cost benefit analysis models and venue management plans
- 5.2 Governance & Leadership:** Forward planning and implementation of plans to determine Strategic Plan and service levels
- 5.3 Governance & Leadership:** Provide informed and transparent decision making that, meets our legal obligations, and the needs of our diverse community
- 5.4 Governance & Leadership:** Implement systems and processes that meet legislative and audit obligations

**CONSULTATION**

Not applicable.

**RISK MANAGEMENT PRIORITIES**

This report addresses the following identified Strategic Risk Management Priorities:

Lack of routine maintenance of Shire roads creates public safety risk and associated liability issues.

Asset Management Plan is non-compliant due to aging assets and increasing costs.

Financial misconduct by (a) a Shire employee, and (b) an executive/office holder results in financial, legal and/or reputational damage.

**RISK ASSESSMENT**

Financial	<p><b>MEDIUM</b></p> <p><i>Our current trucks are limping along and need replacement. Should Council not proceed with the tender, repairs will be costly, or pricing will only increase in coming years.</i></p>
Health	N/A
Reputation	<p><b>HIGH</b></p> <p><i>The Shire uses the 6-wheel tippers frequently for both our Shire works as well as private jobs from members of the community. It allows us to have capacity to respond to road maintenance needs swiftly and with precision.</i></p>

Operations	<p><b>MEDIU</b></p> <p><i>Not having reliable trucks has a major impact on operations. We are currently working on funded road programmes and need to get the work finished in a timely manner and to a high standard.</i></p>
Natural Environment	<p><b>LOW</b></p> <p><i>Newer trucks have better environmental controls and technology for emission reduction.</i></p>

	Consequence				
Likelihood	Insignificant	Minor	Moderate	Major	Critical
Rare	LOW Accept the risk Routine management	LOW Accept the risk Routine management	LOW Accept the risk Routine management	MEDIUM Specific responsibility and treatment	HIGH Quarterly senior management review
Unlikely	LOW Accept the risk Routine management	LOW Accept the risk Routine management	MEDIUM Specific responsibility and treatment	MEDIUM Specific responsibility and treatment	HIGH Quarterly senior management review
Possible	LOW Accept the risk Routine management	MEDIUM Specific responsibility and treatment	MEDIUM Specific responsibility and treatment	HIGH Quarterly senior management review	HIGH Quarterly senior management review
Likely	MEDIUM Specific responsibility and treatment	MEDIUM Specific responsibility and treatment	HIGH Quarterly senior management review	HIGH Quarterly senior management review	EXTREME Monthly senior management review
Almost certain	MEDIUM Specific responsibility and treatment	MEDIUM Specific responsibility and treatment	HIGH Quarterly senior management review	EXTREME Monthly senior management review	EXTREME Monthly senior management review

**COMMENT**



## REQUEST FOR TENDER

### REQUEST FOR TENDER – RFT 01/2023

The Shire of Quairading is seeking to purchase two (2) 6-wheel Tip Truck, capable of at least 13-tonne payload, with side and end tipping capabilities.

The following specifications must also be included:

- GVM of between 20,000 and 30,00kg
- GCM of between 40,000 and 50,000kg
- Tipping Body
  - To be supplied only from Howard Porter or Bruce Rock Engineering
  - Tipping action shall be of a side and end tipping configuration
  - Steel construction (preference may be given to a higher quality construction of tipping body taking into consideration budget allocations)
    - Minimum 5mm thick steel floor
    - Minimum 5mm thick steel front wall and sides
    - Minimum 5mm thick steel tail/side gate
  - Hoist and Hydraulics
    - To suit make and model of truck
    - Must be under body mounted
    - Tipping activation controls (for both the truck and trailer) shall be located inside the cab of the truck in an easily accessible location for the driver.
- Supplier must provide a Parrot Beak Hitch at the rear of the truck with hose fitting configurations as per trade-in vehicles (the Shire will continue using existing trailers)
- Electric tarpaulins installed to tipper body prior to delivery with two control switches - one to be located in truck cab on drivers' side in an easily accessible location and one to be located at rear of driver's side of the cab outside of the vehicle, operable when driver is standing on the ground.
- 2x LED beacons (Narva Pulse LED Strobe Part No. 85246A) to be installed at a location higher than the tray on top of the cab of the truck in an easily viewable position from the front and rear of the truck prior to delivery with a control switch (illuminated 'Beacon' rocker switch) to be located on drivers' side in an easily accessible and viewable location. Lights shall not be drilled into the roof of the cab of the truck but must retain the structural and waterproof integrity of the roof.
- Automatic transmission
- Window tinting on all appropriate windows with a weather shield installed on the driver's side window



## REQUEST FOR TENDER

- 80 channel two-way radio installed within easy accessible location (not more than arm lengths from the seated position on the drivers side) for the driver.
- Heavy duty canvas seat covers (for both driver and passenger seats) and heavy duty rubber floor mats in the cab of the truck
- Price to be inclusive of delivery to Shire of Quairading depot with Handover of new vehicle provided by the successful supplier.
- The delivery of the vehicle without any of the items as outlined within the specifications above (or installed to the required specifications) will be sent back to the supplier at their cost (and redelivery of the amended vehicle). The cost of all remedial works to meet the required specifications as outlined above shall be entirely at the suppliers cost. In the case of a trade in vehicle with this quote, the trade in vehicle shall be retained (without cost penalty/reduction due to having to remedy the works for the new vehicle by the supplier) until such time as the new vehicle is delivered to the Shire of Quairading (depot) by the supplier.
- The supplier shall be deemed to have made themselves fully aware of the specifications of the new vehicle and trade-in vehicles. Relying on details provided by the Shire representative's either verbally or by correspondence shall not hold the Shire (or the representative) responsible for those details disclosed/provided.
- Canvassing of Shire Councillors shall instantly disqualify the suppliers submission.
- The trade-in vehicles are to be considered as-is-where-is and once traded is entirely at the suppliers consideration (no further correspondence/consideration shall be entered in to with the Shire of Quairading) once traded/purchased.
- The Shire may choose to not accept any tenders entirely at their own discretion.
- The Shire may choose to not accept the lowest tender entirely at their own discretion.
- The supplier should give an indication of the timeframe in which the new trucks will be ready for delivery to the Shire of Quairading as part of their response to this RFT.

The Shire will potentially be disposing of two trucks as part of this procurement and a trade-in price should be provided by the successful bidder. Details of the trade vehicles are below. An in-person inspection of the trade-in vehicles at the Shire's Depot is highly encouraged. Any further enquiries should be directed to the Shire's Executive Manager of Works and Services, Sarah Caporn on 0427 451 001 or [sarah.caporn@quairading.wa.gov.au](mailto:sarah.caporn@quairading.wa.gov.au).



**REQUEST FOR TENDER**

**TRUCK 1:**

Current Rego: & approx. ODO Q 272, 192,150	VIN: JNBCWB5EL00L00480	Model & Year of Manufacture: Nissan UD Quon 26 380, 2013
		

**TRUCK 2:**

Current Rego: & approx. ODO Q 5122, 265 571	VIN: JNBGWB4DL00H00724	Model & Year of Manufacture: Nissan UD GW 26 400, 2012
		





## REQUEST FOR TENDER

TENDER DETAILS	
Tender No.	RFT No.01/2023
Tender Title	2 X 6 WHEEL TIP TRUCKS
Description	The Shire of Quairading requests quotes for the supply of two (2) 6-wheeler two way tip trucks.
Allocation within the Budget	\$292,702 x 2 = \$585,404
GL Code / Job ID	PE12303 & PE12317
Particulars of the decision to invite Tenders	Council Resolution OCM037-23/24-August 2023 (Adoption of Annual Budget 2023/24)
Tender Deadline Date and Time <i>(Minimum 14 days)</i>	Thursday 12 <sup>th</sup> October, 5pm
Advertisement Details:	
RFT File Path	<a href="#">T:\23 - PLANT, EQUIPMENT AND STORES\04. TENDERING</a>
WALGA eQuotes / Vendor Panel: VP 380815	
Opened 19 <sup>th</sup> September, Closed 12 <sup>th</sup> October	

TENDERS RECEIVED			
Tender Opening Date and Time:	Tenders opened at _9.00__am/pm on 16/10/2023		
Tenders opened in the presence of: <i>(an Executive staff member must be present)</i>	<table border="1"> <tr> <td>Name: Sarah Caporn Dean Mastin Jason Lilleyman</td> <td>Signature: </td> </tr> </table>	Name: Sarah Caporn Dean Mastin Jason Lilleyman	Signature: 
Name: Sarah Caporn Dean Mastin Jason Lilleyman	Signature: 		
Tenderers:			
1.	UD Trucks		
2.	Daimler Trucks, Fuso		
3.	Major Motors, Isuzu		
4.	Iveco Trucks Australia		
5.			



**REQUEST FOR TENDER**

COUNCIL RESOLUTION & SUCCESSFUL TENDERER		
Was this decision by Delegated Authority?	Yes	No
Record of Decision		
Council Meeting Date: Audit & Risk Subcommittee November 2023 OCM	Resolution No: TBC	

Successful Tenderer	
Value of Successful Tender	



09/11/2023, 12:48

vendorpanel.com.au/Members/

WALGA
My Requests
Videos
Help centre

! You have 3 requests overdue for finalization. [Click here](#) to evaluate responses or extend finalization dates.

**To-Do Tasks**

Evaluate and decide on responses 2

Requests to finalize 1

### My Requests

View all requests
Create new
Pick from template

---

**Statistics for this Request**

**Name:** Plant Acquisition - 2 x Tipper Trucks  
**Ref:** VP380815

SUPPLIER DETAILS	NOTIFIED	DATE FIRST READ	SUPPLIER RESPONDED
1:  Hino Motor Sales Australia Pty Ltd	<input checked="" type="checkbox"/> Yes	<input checked="" type="checkbox"/> 21/Sep/2023 09:07 AM	<span style="color: orange;">✘ Declined to respond</span>
2:  Paccar Australia Pty. Ltd. (previously known as PACCAR Kenworth)	<input checked="" type="checkbox"/> Yes	<input checked="" type="checkbox"/> 20/Sep/2023 10:25 AM	<input type="checkbox"/> None
3:  Volvo Trucks	<input checked="" type="checkbox"/> Yes	<input type="checkbox"/> Not read	<input type="checkbox"/> None
4:  Mack Trucks	<input checked="" type="checkbox"/> Yes	<input checked="" type="checkbox"/> 28/Sep/2023 02:56 PM	<input type="checkbox"/> None
5:  DENNIS EAGLE COMMERCIAL VEHICLES (previously known as DENNIS EAGLE TRUCKS (Dist. by Penske Australia))	<input checked="" type="checkbox"/> Yes	<input type="checkbox"/> Not read	<input type="checkbox"/> None
6:  Adt Western Australia Pty Ltd	<input checked="" type="checkbox"/> Yes	<input type="checkbox"/> Not read	<span style="color: red;">✘ Declined to respond</span>
7:  Brooks Equipment	<input checked="" type="checkbox"/> Yes	<input type="checkbox"/> Not read	<input type="checkbox"/> None
8:  Clark Equipment Sales Pty Ltd	<input checked="" type="checkbox"/> Yes	<input type="checkbox"/> Not read	<span style="color: red;">✘ Declined to respond</span>
9:  MCINTOSH & SON W.A. (previously known as McIntosh and Son)	<input checked="" type="checkbox"/> Yes	<input type="checkbox"/> Not read	<span style="color: red;">✘ Declined to respond</span>
10:  BCI SALES PTY LTD / TRUCK SALES PTY LTD	<input checked="" type="checkbox"/> Yes	<input type="checkbox"/> Not read	<input type="checkbox"/> None
11:  UD TRUCKS a division of Volvo Group Australia	<input checked="" type="checkbox"/> Yes	<input checked="" type="checkbox"/> 28/Sep/2023 04:06 PM	<input checked="" type="checkbox"/> Responses received





Date 11/10/2023  
Quote No. HT2023000315  
Version 2  
Alternative 1

CW 26 460 (11 litre) 6x4 Leaf Suspension.  
(4285mm wheelbase)  
VP380815 – Truck 1



**Quote For**  
Shire of Quairading

**By**  
Trent Harris  
Truck Centre (WA) Pty Ltd

**Going the Extra Mile**

UD is a brand of Volvo Group Australia Pty Ltd  
ABN 27 000 761 259



UD TRUCKS  
udtrucks.com.au



Date 11/10/2023  
 Quote No. HT12023000315  
 Version 2  
 Alternative 1

Your ref. **VP380815**

Shire of Quairading  
 10 Jennaberring Street  
 QUAIRADING  
 WA 6383

## Quotation and Technical Specifications

Dear Sarah,

Truck Centre WA is pleased to provide the following quotation for your consideration. Please do not hesitate to contact me if you require any further information, or wish to modify the specification outlined.

### **1 X CW 26 460 (11 litre) 6x4 Leaf Suspension. (4285mm wheelbase)**

\*Cab Chassis Arriving March 2024\*

#### **Truck Use**

6 WHEELS THERE OF 4 DRIVING  
 Gross Combination Weight 60.0 tonnes

#### **Core Components**

JAPAN 2025 EMISSION REGULATION FOR FCR  
 460HP  
 ESCOT-VI 12 Speed Automated Transmission (Overdrive)  
 11 L. PROPRIETARY ENGINE  
 Single Reduction Tandem Axles  
 Rear Axle Ratio 4.50

#### **Chassis**

BATTERY BOX NORMAL  
 FRONT SUSPENSION APPLICATION STANDARD  
 Wheelbase 3600mm (C/L steer to C/L first drive)  
 Front Parabolic Leaf Spring (stiffer than normal)  
 400 Litre LHS Rectangular Aluminium Fuel Tank 620mm High  
 REAR FRAME LENGTH, 2745 MM  
 TAIL LAMP LED

---

#### **Going the Extra Mile**

UD is a brand of Volvo Group Australia Pty Ltd  
 ABN 27 000 761 259



udtrucks.com.au



Date 11/10/2023  
 Quote No. HT2023000315  
 Version 2  
 Alternative. 1

#### Rims and Tyres

Steer Tyre 295/80R22.5  
 Bridgestone R150Z  
 Steel Rims  
 Drive Tyre 11R22.5  
 Bridgestone M711AZ  
 Steel Rims  
 Bridgestone Brand  
 Spare Rim/Tyre Same as Front

#### Powertrain Equipment

Rear Engine PTO With Splined Shaft Groove (Female) DIN 5462  
 Transmission PTO Prep Kit (dash switch & solenoid)  
 LOW AIR INTAKE

#### Cab Interior

Steering wheel material - standard  
 Decor Accent Strip - Standard  
 Belt In Seat for Driver (Standard Seat Belt for Passenger)  
 Auxiliary Passenger Seat  
 Vinyl Floor Material

#### Cab Exterior

BACK OF CAB ACCESS, EATS  
 Wiring Prep kit for Roof Warning Lamps  
 Sleeper Cab  
 Polar White  
 With Fixed Rear Window Back of Cab  
 Auxiliary Side Windows - Both Sides of cab  
 Front Close View Mirror  
 Standard Grill

#### Superstructure Preparations

BB ELECT. CENTER & CAB BB MODULE, 10 HIG & 4 LOW DIG. OUTLET

#### Safety Features

TRAFFIC SIGN RECOGNITION SYSTEM  
 BRAKE LIGHT EMERGENCY  
 Traffic Eye Brake (Emergency Braking) & Traffic Eye Cruise (Adaptive Cruise Control)  
 ACC WITH STOP AND GO  
 Lane Departure Warning System  
 LANE CHANGE SUPPORT WITH COLLISION WARNING, BOTH SIDES

-

#### Going the Extra Mile

UD is a brand of Volvo Group Australia Pty Ltd  
 ABN 27 000 761 259



udtrucks.com.au



Date 11/10/2023  
 Quote No. HT2023000315  
 Version 2  
 Alternative 1

**Telematic Services**

Telematics Gateway with 4G/LTE & WLAN  
 DYNAFLEET FUEL & ENV 1Y PREPAID  
 DYNAFLEET POSITIONING 1Y PREPAID

**Internal Workshop**

Factory Engine Driven PTO with PTO Programming to Suit  
 2 Way Tipper Application (Live Drive Set-Up)  
 Air & Electrics to Rear Rigid Includes ABS Harness  
 Window Tint  
 Seat Covers - Genuine UD Canvas - Quon  
 Floor Mats Carpet - New Quon  
 Dash Mat - New Quon  
 Weather Shields - New Quon Drivers Side RHS  
 Cab Gun Blower - Beside Drivers Seat  
 Battery - Isolation Switch  
 UHF Radio - Mini/Compact  
 Stone Guard - New Quon  
 Delivery to Shire Depot and Onsite Hand Over

**External Workshop**

Hardox 2 Way Tipping Body as Per Park Bodybuilders Quote Number: SK23-10-02

<b>Vehicle Price Ex-GST:</b>	<b>\$ 266,494.00</b>
GST:	\$26,649.00
Vehicle Price Incl. GST:	\$ 293,143.00
<b>Trade-In Ex-GST:</b>	
2013 UD CW26 380 6x4 2 Way Tipper Rego Number: Q272	- \$90,909.00
GST:	-\$9,091.00
Total Trade-In Price (Incl. GST)	-\$100,000.00
Stamp Duty: <b>Local Government *Stamp Duty Exempt*</b>	
License: <b>At Customers Cost *Local Government Concession*</b>	
<b>Total Drive Away Price Incl. GST (Change Over):</b>	<b>\$ 193,143.00</b>

**Going the Extra Mile**

UD is a brand of Volvo Group Australia Pty Ltd  
 ABN 27 000 761 259





Date 11/10/2023  
Quote No. HT2023000315  
Version 2  
Alternative 1

#### Delivery Date

Delivery date will be affected as near as practicable to the date required by purchaser. Where delivery is made other than at the Truck Centre WA Pty Ltd dealership the purchaser will be responsible for risk between the dealership and the delivery point.

#### Trade In Valuations

Where a trade in valuation is made, the valuation is subject to reappraisal within 30 days from the date of initial appraisal. Also please note that unless stated by the client at the time of the valuation a spare Tyre, working jack and tool kit are assumed to be with the trade in and are expected to be with the trade at the time of change over. Furthermore, the trade in is valued as having a similar Tyre tread as when inspected.

#### Payment

Normal terms of trade are "Cash on Delivery" by Bank cheque or "EFT" into our nominated bank account.

Where the vehicle is to have modifications and/or body fitted, full settlement to take place two weeks after being advised that the truck is ready for delivery to body builder.

#### Prime Supplier

Truck Centre WA Pty Ltd limits its responsibility as the prime supplier to the cab chassis only. This proposal is submitted on the basis that the purchaser accepts that the prime supplier of all other equipment is the selected supplier of that equipment and that claims in respect of warranty, insurance or any other matter will be directed to the supplier of such equipment.

#### FINANCE

Truck Centre's resident finance specialists have more than 30 years combined industry experience. Whether offering the manufacturers own finance (Mack, UD, Volvo) or bank funding our finance specialists can tailor financial services packages to suit your business/cash flow needs. Our Dealership Finance Manager Rob Munro (0416 845 740) will be in contact shortly to discuss the financial services packages available.

Yours sincerely

Trent Harris

Date: 11-10-2023

Truck Centre (WA) Pty Ltd

---

#### Going the Extra Mile

UD is a brand of Volvo Group Australia Pty Ltd  
ABN 27 000 761 259

80<sup>th</sup>  
Anniversary



UD TRUCKS  
udtrucks.com.au



Date 11/10/2023  
Quote No. HT2023000315  
Version 2  
Alternative 1

CW 26 460 (11 litre) 6x4 Leaf Suspension.  
(4285mm wheelbase)  
VP380815 – Truck 2



**Quote For**  
Shire of Quairading

**By**  
Trent Harris  
Truck Centre (WA) Pty Ltd

**Going the Extra Mile**

UD is a brand of Volvo Group Australia Pty Ltd  
ABN 27 000 761 259



UD TRUCKS  
udtrucks.com.au



Date 11/10/2023  
 Quote No. HT12023000315  
 Version 2  
 Alternative 1

Your ref. **VP380815**

Shire of Quairading  
 10 Jennaberring Street  
 QUAIRADING  
 WA 6383

## Quotation and Technical Specifications

Dear Sarah,

Truck Centre WA is pleased to provide the following quotation for your consideration. Please do not hesitate to contact me if you require any further information, or wish to modify the specification outlined.

### **1 X CW 26 460 (11 litre) 6x4 Leaf Suspension. (4285mm wheelbase)**

\*Cab Chassis Arriving March 2024\*

#### **Truck Use**

6 WHEELS THERE OF 4 DRIVING  
 Gross Combination Weight 60.0 tonnes

#### **Core Components**

JAPAN 2025 EMISSION REGULATION FOR FCR  
 460HP  
 ESCOT-VI 12 Speed Automated Transmission (Overdrive)  
 11 L. PROPRIETARY ENGINE  
 Single Reduction Tandem Axles  
 Rear Axle Ratio 4.50

#### **Chassis**

BATTERY BOX NORMAL  
 FRONT SUSPENSION APPLICATION STANDARD  
 Wheelbase 3600mm (C/L steer to C/L first drive)  
 Front Parabolic Leaf Spring (stiffer than normal)  
 400 Litre LHS Rectangular Aluminium Fuel Tank 620mm High  
 REAR FRAME LENGTH, 2745 MM  
 TAIL LAMP LED

---

#### **Going the Extra Mile**

UD is a brand of Volvo Group Australia Pty Ltd  
 ABN 27 000 761 259



udtrucks.com.au



Date 11/10/2023  
 Quote No. HT2023000315  
 Version 2  
 Alternative 1

#### Rims and Tyres

Steer Tyre 295/80R22.5  
 Bridgestone R150Z  
 Steel Rims  
 Drive Tyre 11R22.5  
 Bridgestone M711AZ  
 Steel Rims  
 Bridgestone Brand  
 Spare Rim/Tyre Same as Front

#### Powertrain Equipment

Rear Engine PTO With Splined Shaft Groove (Female) DIN 5462  
 Transmission PTO Prep Kit (dash switch & solenoid)  
 LOW AIR INTAKE

#### Cab Interior

Steering wheel material - standard  
 Decor Accent Strip - Standard  
 Belt In Seat for Driver (Standard Seat Belt for Passenger)  
 Auxiliary Passenger Seat  
 Vinyl Floor Material

#### Cab Exterior

BACK OF CAB ACCESS, EATS  
 Wiring Prep kit for Roof Warning Lamps  
 Sleeper Cab  
 Polar White  
 With Fixed Rear Window Back of Cab  
 Auxiliary Side Windows - Both Sides of cab  
 Front Close View Mirror  
 Standard Grill

#### Superstructure Preparations

BB ELECT. CENTER & CAB BB MODULE, 10 HIG & 4 LOW DIG. OUTLET

#### Safety Features

TRAFFIC SIGN RECOGNITION SYSTEM  
 BRAKE LIGHT EMERGENCY  
 Traffic Eye Brake (Emergency Braking) & Traffic Eye Cruise (Adaptive Cruise Control)  
 ACC WITH STOP AND GO  
 Lane Departure Warning System  
 LANE CHANGE SUPPORT WITH COLLISION WARNING, BOTH SIDES

-

#### Going the Extra Mile

UD is a brand of Volvo Group Australia Pty Ltd  
 ABN 27 000 761 259



udtrucks.com.au





Date 11/10/2023  
 Quote No. HT2023000315  
 Version 2  
 Alternative 1

**Telematic Services**

- Telematics Gateway with 4G/LTE & WLAN
- DYNAFLEET FUEL & ENV 1Y PREPAID
- DYNAFLEET POSITIONING 1Y PREPAID

**Internal Workshop**

- Factory Engine Driven PTO with PTO Programming to Suit
- 2 Way Tipper Application (Live Drive Set-Up)
- Air & Electrics to Rear Rigid Includes ABS Harness
- Window Tint
- Seat Covers - Genuine UD Canvas - Quon
- Floor Mats Carpet - New Quon
- Dash Mat - New Quon
- Weather Shields - New Quon Drivers Side RHS
- Cab Gun Blower - Beside Drivers Seat
- Battery - Isolation Switch
- UHF Radio - Mini/Compact
- Stone Guard - New Quon
- Delivery to Shire Depot and Onsite Hand Over

**External Workshop**

Hardox 2 Way Tipping Body as Per Park Bodybuilders Quote Number: SK23-10-02

<b>Vehicle Price Ex-GST:</b>	<b>\$ 266,494.00</b>
GST:	\$26,649.00
Vehicle Price Incl. GST:	\$ 293,143.00
<b>Trade-In Ex-GST:</b>	
2012 UD GW26 400 6x4 2 Way Tipper Rego Number: Q5122	-\$81,818.00
GST:	-\$8,182.00
Total Trade-In Price (Incl. GST)	-\$90,000.00
Stamp Duty: <b>Local Government *Stamp Duty Exempt*</b>	
License: <b>At Customers Cost *Local Government Concession*</b>	
<b>Total Drive Away Price Incl. GST (Change Over):</b>	<b>\$ 203,143.00</b>

**Going the Extra Mile**

UD is a brand of Volvo Group Australia Pty Ltd  
 ABN 27 000 761 259





Date 11/10/2023  
Quote No. HT2023000315  
Version 2  
Alternative 1

#### Delivery Date

Delivery date will be affected as near as practicable to the date required by purchaser. Where delivery is made other than at the Truck Centre WA Pty Ltd dealership the purchaser will be responsible for risk between the dealership and the delivery point.

#### Trade In Valuations

Where a trade in valuation is made, the valuation is subject to reappraisal within 30 days from the date of initial appraisal. Also please note that unless stated by the client at the time of the valuation a spare Tyre, working jack and tool kit are assumed to be with the trade in and are expected to be with the trade at the time of change over. Furthermore, the trade in is valued as having a similar Tyre tread as when inspected.

#### Payment

Normal terms of trade are "Cash on Delivery" by Bank cheque or "EFT" into our nominated bank account.

Where the vehicle is to have modifications and/or body fitted, full settlement to take place two weeks after being advised that the truck is ready for delivery to body builder.

#### Prime Supplier

Truck Centre WA Pty Ltd limits its responsibility as the prime supplier to the cab chassis only. This proposal is submitted on the basis that the purchaser accepts that the prime supplier of all other equipment is the selected supplier of that equipment and that claims in respect of warranty, insurance or any other matter will be directed to the supplier of such equipment.

#### FINANCE

Truck Centre's resident finance specialists have more than 30 years combined industry experience. Whether offering the manufacturers own finance (Mack, UD, Volvo) or bank funding our finance specialists can tailor financial services packages to suit your business/cash flow needs. Our Dealership Finance Manager Rob Munro (0416 845 740) will be in contact shortly to discuss the financial services packages available.

Yours sincerely

Trent Harris

Date: 11-10-2023

Truck Centre (WA) Pty Ltd

---

#### Going the Extra Mile

UD is a brand of Volvo Group Australia Pty Ltd  
ABN 27 000 761 259

80<sup>th</sup>  
Anniversary



udtrucks.com.au



7 JACKSON STREET  
 BASSENDEAN, WA 6054  
 TELEPHONE: 08 9378 0600  
 FAX: 08 9378 2670  
[www.parkbodybuilders.com.au](http://www.parkbodybuilders.com.au)

**PARK BODY BUILDERS**

CLIENT NAME: **TCWA / Shire of Quairading** QUOTE No: **SK23-10-02**  
 CONTACT: **Trent** CLIENT SPEC No: **UD CW26 460 6x4**  
 PHONE No: FAX or Email:

**HARDOX 2-WAY TIPPING BODY**

Park Body Builders are pleased to submit the following quotation

**MANUFACTURE & FIT (1) ONLY approx. 4.5m x 2.5m x 1m STEEL TIPPING BODY COMPLETE WITH :**

- Floor:** 5mm Hardox (or equivalent) on PFC main members
- Cab Shield:** 5mm Hardox (or equivalent) complete with tarp tie down points, broom holder & shovel holder
- Sides:** 5mm Hardox (or equivalent) with top tubes on diamond. LH side fixed, RH side Hydraulic cylinders operated
- Tail Gate:** 5mm Hardox (or equivalent) top & side swing inc air operated locking system
- Access Step:** Pull out step to LHS and grab handles painted yellow
- Hoist:** Under body hoist to suit including air operated end of stroke valve and separate safety chain
- Hydraulics:** Air operated PTO (to suit manual gear box) incl. 75 L oil tank & air operated tip valve
- Subframe:** Full length SHS sub frame incorporating hoist, pivots
- Safety prop:** Manual operated safety prop
- Mud Guards:** Steel mudguards to body
- Painting:** To be mechanically cleaned, primed and painted in 2-pack finish to match the cabin (white)
- Underside:** Painted black to match the chassis
- Lighting:** Transfer tail lights from truck in accordance with traffic regulations

<b>Quoted by:</b> Simon Kenny	<b>Date:</b> 26/09/2023	<b>SUBTOTAL</b>	<b>\$ 76,500.00</b>
<b>Quotation Validity:</b> This Quotation is Valid for 30 Days Only		<b>10% GST</b>	<b>\$ 7,650.00</b>
<b>Terms of Payment:</b> C.O.D. or AS ARRANGED		<b>TOTAL</b>	<b>\$ 84,150.00</b>

**INCLUDED EXTRAS:**

Engine driven PTO housing standard ex factory; PBB to set hydraulics up to suit live drive PH-300 (or equivalent) only  
 Note: TCWA advises that air, elec & ABS lines will be present at rear of chassis with couplings already fitted  
 Hydraulics to rear including air operated diverter valve & larger oil tank as required to suit Shire's existing trailer  
 Additional air line & switching to suit Shire's existing trailer  
 Electric Crank & Go retractable (front to back) tarp two control switches - one to be located in truck cab on drivers' side in an easily accessible location and one to be located at rear of driver's side of the cab outside of the vehicle, operable when driver is standing on the ground.  
 2x LED beacons (Narva Pulse LED Strobe Part No. 85246A) to be installed at a location higher than the tray on top of the cab of the truck in an easily viewable position from the front and rear of the truck prior to delivery with a control switch (illuminated 'Beacon' rocker switch) to be located on drivers' side in an easily accessible and viewable location. Lights shall not be drilled into the roof of the cab of the truck but must retain the structural and waterproof integrity of the roof

We trust your requirements have been interpreted correctly both technically and commercially. Should you require any additional information please do not hesitate to contact Simon Kenny on 08-9378-0600, 0417002457 or [simonkenny@parkbodybuilders.com.au](mailto:simonkenny@parkbodybuilders.com.au)

**Deposit; 30% REQUIRED** **Delivery; T.B.A**  
**Payment; ON COMPLETION** **GST; 10% TO ALL PRICES**  
 All quotes valid; (fixed & firm) for 30 days and subject to Park Motor Body Builders Standard Terms and Conditions  
 A copy of which is available on request.

**ACCEPTANCE OF QUOTE/SPECIFICATION and AUTHORITY TO PROCEED BY PURCHASER (must be signed)**

Accepted; \_\_\_\_\_ For \_\_\_\_\_ Order No; \_\_\_\_\_ Date; / /



# QUON 11-Litre

CW 26 400 | 460

6x4 Rigid



## SPECIFICATIONS

<b>Power:</b>	GH11TB - 294 kW (400 PS) @ 1600 rpm GH11TD - 338 kW (460 PS) @ 1700 rpm
<b>Torque:</b>	GH11TB - 2000 Nm (1475 lb.ft) @ 950 rpm GH11TD - 2250 Nm (1659 lb.ft) @ 1000 rpm
<b>Transmission:</b>	ESCOT-VI automated manual transmission (AMT)
<b>Rear Suspension:</b>	Leaf spring or electronically controlled air suspension
<b>Wheelbase:</b>	Refer weights and dimensions table
<b>GVM:</b>	26,000 kg
<b>GCM:</b>	50,000 kg (400hp) 60,000 kg (460hp)

## QUON UNIQUE FEATURES

- 
**NEW SMART FUEL EFFICIENT ENGINES WITH RESPECT FOR THE ENVIRONMENT**  
 GH11 engine: fuel efficient, powerful and clean
- 
**SMART UPTIME**  
 Quon has been designed to further optimise uptime, with superior reliability and increased maintenance intervals.
- 
**SMART SAFETY**  
 Active safety with mechanical and electronic features throughout, including safety for vulnerable road users.
- 
**SMART PRODUCTIVITY**  
 Light weight chassis helping to maximise payload. New engines with improved horsepower and torque to increase productivity.
- 
**SMART DRIVABILITY**  
 The cabin has been designed with the user's comfort in mind, with outstanding ergonomics and visibility allowing the driver to concentrate on driving

**UD Trucks Australia**  
[udtrucks.com/Australia](http://udtrucks.com/Australia)

Last Published June 2023

**GENERAL SPECIFICATIONS**

**ENGINE**

**Model:** GH11TB | GH11TD  
**Description:** 6 cylinder, 4 stroke diesel engine  
**Displacement:** 10,837 cc  
**Bore x stroke:** 123 mm x 152 mm  
**Compression ratio:** 17.5:1  
**Max. governed engine speed:** 2,100 rpm

**GH11TB400PS**

294kW (400PS) @ 1,600rpm  
 2,000Nm (1475 lb-ft)  
 @ 950 -1,350rpm

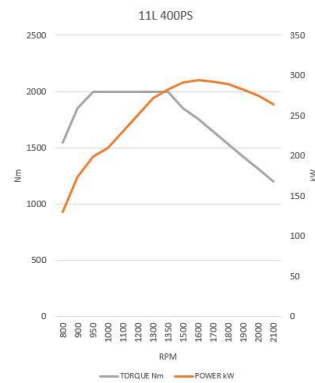

**GH11TD460PS**

338KW(460PS) @ 1,700rpm  
 2,250Nm (1659 lb-ft)  
 @ 1,000 - 1,200rpm

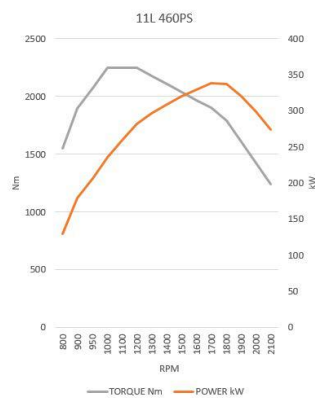

**UD Trucks Australia**  
 udtrucks.com/australia

**SAFETY**

**Passive Safety:** Highly rigid cabin  
 Side door beams  
 Front underrun protection system (FUPS)  
 SRS driver steering wheel airbag  
 Driver side seat belt with pre-tensioner  
 Steering wheel & column with impact absorption function

**Active Safety:** Traffic Eye Brake System  
 Traffic Eye Cruise Control with auto stop and driver initiate go  
 LDWS (Lane Departure Warning System)  
 Electronic Stability Control (UDSC)  
 Automatic Hill Start Assist (HSA)  
 Lane change support LHS & RHS  
 Blind side information system LHS & RHS

**Basic Safety:** LED Headlamps  
 Disc brakes  
 Anti Locking Brake System  
 Emergency Braking System  
 UD Extra Engine Braking (UD EEB)  
 Safe Brake Blending Immobiliser  
 Two-step entry and exit

**FUEL AND INTAKE SYSTEM**

**Fuel capacity:** 400 litres  
**Injection type:** High pressure common rail direct fuel injection system  
**Filtration:** Chassis mounted primary filter and engine mounted secondary filter

**EMISSION CONTROL**

**Emission standard:** pPNLT (equivalent to Euro 6 emission requirements)  
**Adblue capacity:** 50 litres  
**Exhaust system:** RHS chassis mounted box muffler

**ELECTRICAL**

**Power:** 24 volt, negative ground system  
**Battery capacity:** 2 x 12 volt 165 Ah batteries  
**Alternator:** 150 amp

**TRANSMISSION**

**Make:** UD Trucks  
**Model:** ESCOT-VI (AT02612F)  
**Description:** Automated manual transmission (AMT)  
 12 forward & 2 reverse gears  
**Shift type:** Electronic shifter with fully automatic or manual control

**Gear ratios:**

<b>1<sup>st</sup></b>	11.73	<b>7<sup>th</sup></b>	2.70
<b>2<sup>nd</sup></b>	9.21	<b>8<sup>th</sup></b>	2.12
<b>3<sup>rd</sup></b>	7.09	<b>9<sup>th</sup></b>	1.63
<b>4<sup>th</sup></b>	5.57	<b>10<sup>th</sup></b>	1.28
<b>5<sup>th</sup></b>	4.35	<b>11<sup>th</sup></b>	1.00
<b>6<sup>th</sup></b>	3.41	<b>12<sup>th</sup></b>	0.78
<b>Rev 1</b>	13.73	<b>Rev 2</b>	10.78

**PTO capacity:** 500 Nm @ 103% or 81% (PTR-FH6)  
 1000 Nm @ 115% or 90% (PTR-D)

**FRONT AXLE AND SUSPENSION SYSTEM**

**Ground capacity:** 8,200 kg  
**Axle type:** Reverse Elliot I-Beam  
**Suspension:** Parabolic leaf spring with double acting shock absorbers  
**Spring dimensions:** 90mm x 1460mm  
**Spring constant:** 347.7 N/mm

DISCLAIMER: Imported and distributed by Volvo Group Australia Pty Ltd (ABN: 27 000 761 259). Photos for illustration purposes. Volvo Group Australia Pty Ltd reserves the right to modify design and change equipment without previous notification. Please consult with your UD Trucks Dealer for the latest information about vehicle specifications. **Last Published June 2023**

<b>REAR AXLE AND SUSPENSION SYSTEM</b>	
<b>Ground capacity:</b>	20,000 kg
<b>Axle type / model:</b>	Single reduction, hypoid gear, with cross locks
<b>Final reduction ratio:</b>	4.13, 4.50
<b>LEAF SUSPENSION</b>	
<b>Description:</b>	Multi-leaf spring suspension, with rubber cushions
<b>Leaf dimensions:</b>	75mm x 1380mm
<b>AIR SUSPENSION</b>	
<b>Description:</b>	8 air bag
<b>Shock absorbers:</b>	Telescopic double acting
<b>Road friendly certification number:</b>	RF2099 (air only)
<b>Control system:</b>	Electronic Controlled Air Suspension with remote control mounted in cab (ECAS4)
<b>BRAKES</b>	
<b>Type:</b>	Electronic braking system (EBS) with disc brakes on all axles
<b>Front/Rear:</b>	430 mm rotors / 430 mm rotors
<b>Park brakes:</b>	Hand-operated pneumatic spring park brake on drive axles
<b>Auxiliary brake:</b>	Exhaust plus engine compression type (EEB)
<b>Trailer connections:</b>	Air and electrical connections to rear of chassis
<b>STEERING</b>	
<b>Type:</b>	Recirculating ball and screw with hydraulic assist
<b>Steering gear ratio:</b>	24.1 - 26.8 : 1
<b>Column:</b>	Adjustable, tilt and telescopic control
<b>Steering wheel:</b>	460 mm diameter with ignition key steering lock
<b>WHEELS &amp; TYRES</b>	
<b>Wheels:</b>	8.25in x 22.5in rim with 165mm offset and ISO 10 stud pattern (335mm PCD)
<b>Front tyres:</b>	295/80 R22.5 Bridgestone R150Z
<b>Rear tyres:</b>	11R 22.5 Bridgestone M711AZ
<b>Spare tyre:</b>	295/80 R22.5 Bridgestone R150Z
<b>FRAME</b>	
<b>Width:</b>	850 mm
<b>Side rail dimensions:</b>	300 mm x 90 mm x 8 mm
<b>Material:</b>	Rolled high tensile carbon steel
<b>Tensile strength:</b>	600MPa / 600N/mm <sup>2</sup>
<b>DRIVER INFORMATION &amp; CUSTOMISABLE COLOUR DISPLAY SCREEN</b>	
<b>In Dash Warning Systems:</b>	Visual warning lamps with audible warning tones, plus written warnings displayed in full colour on the information screen
<b>In Dash Driver Information:</b>	Customisable live information includes: On board fuel coaching with economy tips, fuel & AdBlue usage, instant fuel consumption, digital speedo, trip computer including: time, distance & distance to empty. Hour meter, coolant temp, engine oil temp, transmission oil temp, UDPC level, volt meter.

**UD Trucks Australia**  
[udtrucks.com/australia](http://udtrucks.com/australia)

DISCLAIMER: Imported and distributed by Volvo Group Australia Pty Ltd (ABN: 27 000 761 259). Photos for illustration purposes. Volvo Group Australia Pty Ltd reserves the right to modify design and change equipment without previous notification. Please consult with your UD Trucks Dealer for the latest information about vehicle specifications. **Last Published June 2023**

<b>INTERNAL CABIN</b>	
<b>Lighting:</b>	Dual ON/OFF/DOOR interior lights Interior neon cabin lamp
<b>Seating capacity:</b>	Two (three seats optional) ISRI 6860/875 air suspended seat with integrated seat belt & adjustable arm rest.
<b>Driver's seat:</b>	Adjustable height control & rebound damper. With split seat back adjustments for recline & head rest position. Seat base tilt, seat cushion slide, seat air dump switch. Adjustable air bladders (4) for side bolsters, upper & lower lumbar
<b>Passenger seat/s:</b>	Assistant seat with adjustable back & head rest
<b>Sleeping capability:</b>	ADR 42/04 compliant sleeper bunk with mattress and full curtains
<b>Side windows:</b>	Power operated door glass
<b>Security:</b>	Remote central locking with immobiliser
<b>Air conditioning:</b>	Fully automatic climate controlled air conditioning with recirculation filter
<b>Multimedia unit:</b>	8 inch high definition capacitive touchscreen with tilting function, AM-FM radio, digital radio & internet radio (requires phone data), USB & auxiliary ports & PDF reader, standard WDR digital reverse camera with microphone & infrared function, four additional camera capable, Wi-Fi & phone tethering enabled, Bluetooth handsfree operation, Android connectivity, Apple connectivity with Siri inputs, truck specific satellite navigation with 3 free map upgrades. Options available: Cordless Qi rated phone charging pocket, tyre pressure monitoring & reverse sensors
<b>Storage:</b>	Multiple in-cab compartments
<b>Power outlet:</b>	24 volt 240W & 12 volt 120W in dash
<b>DIN accessory fitment:</b>	Two DIN sized compartments
<b>Floor covering:</b>	Vinyl
<b>EXTERNAL CABIN</b>	
<b>Cab Description:</b>	Forward control, pressed steel construction
<b>Mounting type:</b>	Full floating, 4 bag air suspended cab with 4 dual acting shock absorbers and dual automatic height control valves.
<b>Cab paint:</b>	Standard – Polar White
<b>Inspection points:</b>	Back of the cab and front panel
<b>Bumper type:</b>	3 piece with steel corner panels
<b>Mirrors:</b>	Heated and electrically operated main mirrors with flat glass, wide vision and passenger-side downward facing spot mirrors
<b>Lamps:</b>	LED head lamps (low beam) Bumper mounted fog lamps Roof mounted clearance lights
<b>Wipers:</b>	Triple arm, 2 speed wipers with variable intermittent operation and integrated washers
<b>Reversing system:</b>	Reverse beeper and digital infrared camera with microphone

**GENERAL SPECIFICATIONS**

**FACTORY OPTIONAL EQUIPMENT**

<b>Tyres:</b>	275/70 R22.5
<b>Wheels:</b>	Alcoa aluminium wheels
<b>Rear engine PTO:</b>	DIN 5462 or Flange SAE1410; 650 Nm capacity
<b>Safety:</b>	Driver Alert System Driver Monitoring System
<b>Cab Interior:</b>	Leather steering wheel, woodgrain dash, centre console or 2nd passenger seat
<b>Cab Exterior:</b>	Roof scoop, chrome grille, roof beacon prep kit, bumper spoiler, passenger door peep window, cab auxiliary side windows
<b>Additional Wheelbases:</b>	4,250mm, 4,700mm & 5,100mm
<b>Chassis:</b>	Additional 400 litre fuel tank (V wheelbase only), front axle stabiliser.
<b>Cab Paint:</b>	Custom paint colours.

**UD CONNECT (FLEET MANAGEMENT)**

<b>Telematics hardware:</b>	In-cab GSM and GPS unit with SIM-card connected to roof antenna
<b>Subscription:</b>	12 months included
<b>Packages:</b>	Fuel and Environment Positioning
<b>Key Reports:</b>	Total operational time and distance Average speed and fuel consumption Total CO <sup>2</sup> emission Vehicle utilisation Anticipating & braking Engine & gear utilisation Speed adaptation Time idling (standstill)

**WEIGHTS AND DIMENSIONS (approx.)**

Variant	Wheelbase code	Mass (kg)			i) 400HP							Vehicle Dimensions (mm)							UD order code
		GVM*	GCM	Total Tare <sup>1</sup>	WB	TWB	OL	OW	OH	FT	RT	AS	ROH	CA	GC <sup>2</sup>	FHF <sup>2</sup>	FHR <sup>2</sup>	Turning radius (kerb to kerb)	
UD-Leaf	L	26000	50000	7830	3700	4385	7867	2490	2970	2062	1851	1370	2645	2985	249	1022	1091	6900	CW26400LAL
	T	26000	50000	8063	5350	6035	11167	2490	2970	2062	1851	1370	4295	4635	249	1026	1089	9300	CW26400TAL
UD-Air	V	26000	50000	7956	5800	6485	11467	2490	2970	2062	1851	1370	4145	5085	249	1027	1028	9900	CW26400VAA

Variant	Wheelbase code	Mass (kg)			ii) 460HP							Vehicle Dimensions (mm)							UD order code		
		GVM*	GCM	Front Tare <sup>1</sup>	Rear Tare <sup>1</sup>	Total Tare <sup>1</sup>	WB	TWB	OL	OW	OH	FT	RT	AS	ROH	CA	GC <sup>2</sup>	FHF <sup>2</sup>		FHR <sup>2</sup>	Turning radius (kerb to kerb)
UD-Leaf	K	26000	60000	4374	3492	7866	3600	4285	7557	2490	2970	2062	1851	1370	2495	2745	249	1030	1038	6800	CW26460KAL
UD-Air	X	26000	60000	4379	3453	7832	3600	4285	7557	2490	2970	2062	1851	1370	2495	2745	249	1027	1091	6800	CW26460KAA

\*Rated GVM and axle capacities are subject to Federal, State and Territory legal requirements.  
<sup>1</sup>Mass is an estimation only based on standard model, includes fluids (not Diesel fuel or AdBlue) excludes driver and tools. Subject to +3% tolerance.  
<sup>2</sup>Based on vehicle with standard wheels and tyres.  
<sup>3</sup>For alloy rims deduct 56kg from Front Tare and deduct 111kg from Rear Tare.  
<sup>4</sup>For alloy rims add 18mm to both FT and RT measurements.

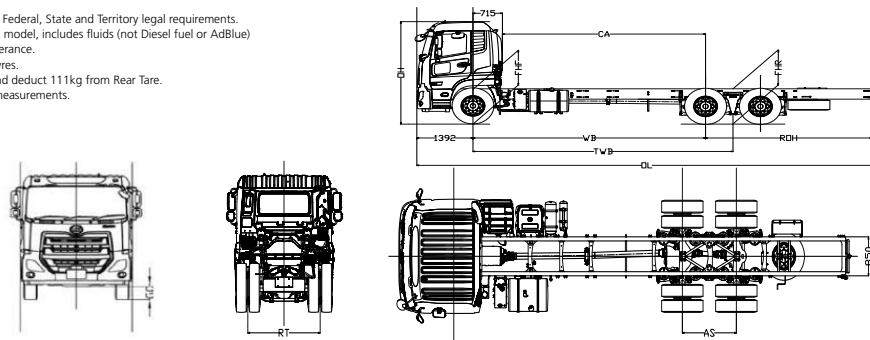

**WARRANTY**

<b>Standard warranty*</b>	36 months / 500,000 kms
<b>Cab corrosion warranty*</b>	36 months / unlimited kms
<b>Extended warranty**</b>	60 months / 500,000 kms

\*For details refer to your UD Trucks New Vehicle Warranty brochure  
 \*\*Purchased by the owner and covers selected factory items only. For details refer to your UD Trucks New Vehicle Warranty brochure

**UD Trucks Australia**  
 udtrucks.com/australia

DISCLAIMER: Imported and distributed by Volvo Group Australia Pty Ltd (ABN: 27 000 761 259). Photos for illustration purposes. Volvo Group Australia Pty Ltd reserves the right to modify design and change equipment without previous notification. Please consult with your UD Trucks Dealer for the latest information about vehicle specifications. **Last Published June 2023**



# QUON – Heavy Duty Standard Warranty



### Coverage Levels

The QUON Truck Warranty is offered with the following coverages to suit the application or segment category.

APPLICATION / CATEGORY	GCM	COVER	MONTHS**	KILOMETRES**
Heavy Duty (HD)	Up to 60 tonnes	Standard	0-36	500,000
		Cab Structure / Corrosion	0-36	Unlimited

Note: \*\* Whichever occurs first – months / kilometres.

### Warranty

For full Warranty terms, conditions, limitations and exclusions, see the *UD Warranty Booklet*.

### Warranty Period

Warranty coverages commence from the delivery date stated on the "Warranty Certificate / Registration Form" contained in the *UD Warranty Booklet*, until "whichever occurs first" months or kilometres.

### Standard Coverage

Includes parts and labour costs to repair or replace defective QUON cab / chassis components only.

### Driveline Coverage - Major Components

Includes parts and labour costs to repair or replace defective major components in the engine, gearbox and final drive.

### Maintenance

If maintenance components do not meet UD Truck specifications the necessary replacement, repair or adjustment will be made without charge if rectified within 120 days or 50,000 kms\*\*, and vibrations within 6 weeks or 15,000 kms\*\* from date of delivery.

### Scheduled Maintenance

The vehicle must be maintained as outlined in the UD Trucks Preventative Maintenance / Service Plan for the standard and Driveline Warranties to remain valid.

UD Truck warranty cannot support claims for any components that are not maintained and/or neglected.

All coolants, oils and filters and other consumables used must meet UD Truck specifications.





## QUON – Heavy Duty Standard Warranty



### What is not covered

**Examples of excluded items which are either part of normal maintenance or wear & tear include:**

- Oil, fuel, air, coolant and air-conditioner filters, drive belts, lubricants, bulbs, fuses, wiper blades, hoses, glass.

**Examples of excluded adjustments which are part of normal maintenance include:**

- Engine valves, wheel and axle alignments, trailer brake valve and tightening of hoses, pipes and bolts.

**Examples of wear and tear items include:**

- Brake discs and pads, clutch plates / linings, clutch packs. Bearings, synchronisers, shock absorbers, bushings, shock absorber rubbers, kingpins, oil seals, universal joints, shackle pins, upholstery, glass, mud flaps, towing couplings, trailer connections.

**Warranty does not cover the following items:**

- Alterations not approved by UD Trucks.
- Any vehicle component, replacement spare part which has been subject to misuse, negligence, improper installation, accident or any service or repair not conducted in accordance with the UD Trucks Preventative Maintenance / Service Plan [or any other applicable manual].
- Failure to apply UD Trucks recommended lubrication / maintenance intervals in accordance with Owner's Manual.
- Consequential, indirect or incidental expenses incurred as a result of defects in manufacturer's material / workmanship.
- Normal deterioration of paint, soft trim and appearance items due to wear and exposure.
- Tyres – these have a separate warranty covered by the tyre manufacturer.
- Normal noise and vibration.

**Warranty does not cover damage / failures / corrosion resulting from the following:**

- Accident, theft, fire, vehicle overload or misuse.
- Use of improper / contaminated fluids, coolants or lubricants.
- Failure to follow schedule maintenance services.
- Use of parts other than genuine UD Truck parts.
- Environmental conditions, acts of God and other events beyond the control of UD Trucks such as wind storm, hail, stone damage, floods or lightning.
- Failure to follow instructions for AdBlue use, storage and handling as described in drivers instruction booklet.

Note: \*\* Whichever occurs first – months / kilometres.

### Important

For the standard & Driveline Warranties to remain valid mandatory warranty services, inspections, downloads, oil sampling and repairs must be completed "prior" to the expiry dates and/or distances detailed.

### Parts Warranty

- 12 months / Unlimited kms from date of purchase, or
- 24 months / 500,000kms for driveline components if part is installed by authorised UD Truck dealer.

**If part is purchased over the counter** from an authorised UD Truck dealer and a warrantable failure occurs, UD Trucks will cover cost of failed part.

**If authorised UD Truck dealer installed the part** and a warrantable failure occurs the part and labour for replacement will be covered including any genuine UD components that are a consequence of this failure.

### Towing and Roadside Assist

Towing and Roadside Assist coverage (trailers not included) is provided to the closest authorised UD Dealer or repairer from:

- 12 months / unlimited kms
- 13-24 months / 500,000kms\*\* on listed driveline components.

### Cab Structure and Corrosion

Cab structure and corrosion coverage from:

- 0-36 months / Unlimited kms

**Note:** Paintwork on the cab and chassis is covered for 12 months only from the warranty start date.

### Warranty transfer

If the truck is sold into the same application or segment category, the balance of the warranty can be transferred at no cost.

If sold into a different application or segment category, some or all of the warranty may be valid.

Please contact your local UD Truck Dealer.

Our goods come with guarantees that cannot be excluded under the Australian Consumer Law. You are entitled to a replacement or refund for a major failure and compensation for any other reasonably foreseeable loss or damage. You are also entitled to have the goods repaired or replaced if the goods fail to be of acceptable quality and the failure does not amount to a major failure. As set out in our sale contract, our liability to you under Part 3-2 of the Australian Consumer Law may be limited by the operation of that contract]. The above text (which we are required to include in this document by the Australian Consumer Law) must be read subject to the operation of the relevant clauses of the sale contract.



UD TRUCKS

# QUON – Heavy Duty Extended Protection Plan



### Eligibility

The extended protection plan is available on all new QUON Models CD / CW / GK / GW. The extended protection plan must be purchased within 60 days of the original delivery date of the vehicle

### Coverage

**37-60 months / 500,000kms\*\***

Repairs are to be carried out by an authorized UD Truck Dealer or their nominated agent. The extended protection plan will cover all listed major component parts. Parts and labour charges will be covered under the extended protection plan

### Components covered

#### Engine

All internally lubricated engine components, intake & exhaust manifolds, turbocharger, flywheel housing, and oil cooler

#### Clutch

Pressure plate

#### Transmission (Auto / Manual)

Internal components (except normal wear & tear, clutch packs, seals, synchronizers/ manual transmission)

#### Propeller shaft

Propeller shaft tube, yoke and flange (except universal joints and center bearings)

#### Front axle

All component parts (except kingpins and bushes)

#### Rear Axle

Rear axle housing

#### Differential

All internal parts (except oil seals)

#### Chassis

Chassis rails and cross members

### Pricing

QUON (All models)

**\$3,810**  
excluding GST

Note: \*\* Whichever occurs first – months / kilometres.



**QUON – Heavy Duty**  
**Extended Protection Plan**



**What is not covered**

**Examples of excluded items which are either part of normal maintenance or wear & tear include:**

- Oil, fuel, air, coolant and air-conditioner filters, drive belts, lubricants, bulbs, fuses, wiper blades, hoses, glass.

**Examples of wear and tear items include:**

- Brake discs and pads, clutch plates / linings, clutch packs. Bearings, synchronisers, shock absorbers, bushings, shock absorber rubbers, kingpins, oil seals, universal joints, shackle pins, upholstery, glass, mud flaps, towing couplings, trailer connections.

**Warranty does not cover damage / failures / corrosion resulting from the following:**

- Accident, theft, fire, vehicle overload or misuse.
- Use of improper / contaminated fluids, coolants or lubricants.
- Failure to follow schedule maintenance services.
- Use of parts other than genuine UD Truck parts.
- Environmental conditions, acts of God and other events beyond the control of UD Trucks such as wind storm, hail, stone damage, floods or lightning.
- Failure to follow instructions for AdBlue use, storage and handling as described in drivers instruction booklet.

**Examples of excluded adjustments which are part of normal maintenance include:**

- Engine valves, wheel and axle alignments, trailer brake valve and tightening of hoses, pipes and bolts.

**Warranty does not cover the following items:**

- Alterations not approved by UD Trucks.
- Any vehicle component, replacement spare part which has been subject to misuse, negligence, improper installation, accident or any service or repair not conducted in accordance with the UD Trucks Preventative Maintenance / Service Plan [or any other applicable manual].
- Failure to apply UD Trucks recommended lubrication / maintenance intervals in accordance with Owner’s Manual.
- Consequential, indirect or incidental expenses incurred as a result of defects in manufacturer’s material / workmanship.
- Normal deterioration of paint, soft trim and appearance items due to wear and exposure.
- Tyres – these have a separate warranty covered by the tyre manufacturer.
- Normal noise and vibration.

Going the Extra Mile.



**UD TRUCKS**

## **UD Trucks Risk Assessment**



## **UD New Quon**

Developed by Bill Manton  
Revised: May 2018



## Contents

UD Trucks Risk Assessment .....	1
UD New Quon.....	1
History .....	3
Reference Standards .....	4
UD Trucks Range.....	4
UD Trucks Compliance.....	5
Risk Management.....	5
Rating the Risk.....	5
Assess the Level of Risk .....	6
Risk Assessment Matrix Guide UD Trucks New Quon Primemover and Rigid .....	7
Vehicle Risk Assessment.....	11
Legal Requirements Owners/Drivers .....	11
Operator Daily Pre-Departure Checks.....	12
Access Behind the Front Bonnet .....	12
Battery Position .....	13
Entering and Exiting the Vehicle .....	14
Parking Brake and Transmission .....	15
Checks Prior to Exiting.....	16
Seat Adjustments .....	17
Interior.....	17
Interior Checks Continue.....	18
Exterior Mirrors .....	18
Checks After Start-Up.....	18
Entry and Exit Access to Chassis.....	20
Checks While Driving.....	21
Additional Features and Information.....	21
Check Points .....	22
Responsibilities of the Owner/Driver.....	24
Guidelines and Legislation.....	24

### Disclaimer

The information contained in this document relies upon material and data, some of which is obtained from several third-party sources and is intended as a guide only in developing risk management systems for the operation of UD Trucks.

Drivers and Vehicle Owners should rely on their own advice, skills and experience in identifying hazards, applying risk and safety management systems. Use of this document does not relieve the user of any obligation or duty that might arise under any legislation (including but not limited to Occupational Health and Safety legislation).

This must include the duties relating to risk management under the Work Health and Safety Act 2011, and any legislation relating to Traffic and Vehicle Regulations. The information in this document is provided to assist and guide users in the recommended use of UD Trucks to minimise risks to health and safety so far as is reasonably practicable.

## History

**UD Trucks Corporation** is a Japanese company whose principal business is the manufacturing and sales of diesel trucks, buses, bus chassis and special-purpose vehicles. Its headquarters are located in Ageo, Saitama, Japan. The company is a wholly owned subsidiary of the Volvo Group since 2007. Before 2010, the company was known as Nissan Diesel.

Today, UD Trucks together with Volvo Group has been the world leaders in introducing to commercial vehicles innovation in design and safety features, which have now become industry best practice, and accepted by competitors as being vital requirements. As an example, being the first turbo charged diesel engine to be fitted into a commercial vehicle and the fitment of seat belts to the Driver and passenger seating positions.

The all-new New Quon with associated services now moves UD Trucks into a stronger position in the truck industry. Combining industry-leading fuel efficiency with dynamism and drivability, the all-new New Quon offers an unparalleled driveline that delivers a smooth, stress-free and comfortable ride. New Quon is equipped with advanced safety features protects the Driver and cargo, but also cares for the safety of the vehicle's surroundings.

"The all-new New Quon of course complies with the new and stricter emission regulations in Japan. In addition, it also delivers better performance across the board. Equipped with the ESCOT-VI, the electronically controlled automated transmission that is the industry benchmark.

UD chassis-cab is manufactured by UD Trucks Japan and supplied by UD Trucks is designed to comply with all applicable Australia Design Rules (ADR) and ECE-R29 Cab Strength Compliant for a partially completed vehicle (PCV) at the time of manufacture. ADR compliance of the cab chassis-cab manufactured by UD Trucks is granted by the (DoIT) Department of Infrastructure and Transport.

Proof of compliance of an individual PCV is shown by a ADR Identification (compliance plate). Various regulations relating to the vehicle performance, equipment and safety have been issued by government organisations. These regulations include but are not limited to the DoIT regulations.

Other Federal, State, Territory and local regulations may also apply. Second-Stage-of-Manufacturer (SSMM), body builders and motor carriers are responsible for knowing and complying with all regulations that may apply to the vehicle. A finished vehicle may also require devices that are not specified in the regulations. SSMM, body builders and motor carriers must determine what safety devices are necessary for the safe operation of the vehicle.

**Information is available on the following links.**

<http://rvcs.dotars.gov.au/>

[http://www.infrastructure.gov.au/roads/motor/design/adr\\_online.aspx](http://www.infrastructure.gov.au/roads/motor/design/adr_online.aspx)

[http://www.infrastructure.gov.au/roads/vehicle\\_regulation/bulletin/vsb\\_06.aspx](http://www.infrastructure.gov.au/roads/vehicle_regulation/bulletin/vsb_06.aspx)

UD Trucks produce a range of trucks specifically designed to suit a market segment, such as local delivery, intrastate and interstate. Each of these market segments require a commercial vehicle with specific attributes that is difficult to provide in a single vehicle design, hence it is very important to ensure that the vehicle you select for your application meets the requirements for Driver comfort, safety, efficiencies, performance and long-lasting reliability.

The UD Trucks New Quon model is designed and ideally suited for the Australian conditions with optional horsepower available up to 460Hp in wheelbase configurations of 4X2, 6X2 and 6x4. The UD Trucks New Quon primemover or rigid vehicles are designed for carrying payloads by either a connected trailer or in/on the fitted body. The final application of the vehicle and its intended use will vary depending on the operators' requirements.

Each of the cabin designs fitted to the various models is specifically designed to ensure the Driver has the safest working environment available for the application, to help improve Driver performance by reducing fatigue. To reduce Driver fatigue, the cabins are isolated from the driveline chassis including Front Underrun Protective Devices (FUPDs) attached to the front of the chassis on all models.

## Reference Standards

The following standards are referenced:

- AS NZS 4024.1201-2014 Safety of machinery - General principles for design - Risk assessment and risk reduction
- AS NZS 4024.1303-2014 Safety of machinery - Risk assessment - Practical guidance and examples of methods
- AS NZS ISO 31000-2009 Risk management - Principles and guidelines

This incorporates detailed sections on the safe operation of the vehicle. A copy of the Owner's Manual is supplied with the vehicles and should be read in conjunction with this risk assessment.

## UD Trucks Range

The UD Trucks New Quon range of vehicles is designed to suit all types of applications.

- Servicing local delivery,
- Local, Intrastate and Interstate operations
  - Bulk commodities e.g. bulk liquids, landscape supplies and quarries
  - Waste,
  - Livestock,
  - Accident/crash recovery vehicles,
  - Construction &
  - General Freight.
- Supply and delivery with a range of body designs options e.g.
  - rigid vehicle fitted with; flattop, pantech, refrigerated and specialised bodies or
  - as a primemover used in various combinations.

**Note:** The New Quon has a comprehensive suite of active & passive safety features included as standard sold within Australia. Other safety items or equipment are optional. Be aware that connecting of non-ABS or EBS equipped trailers to the New Quon will result in some, or all of these new safety features being deactivated or restricted.

Consult your trailer manufacturer regarding your trailer's capabilities & specifications. Please consult your New Quon owner's manual.

The UD Trucks New Quon has been designed to provide easy access for the Driver, Driver's comfort, safety, efficiencies, performance and long-lasting reliability.

- Low cabin access
- Wide opening doors
- Ergonomically designed steps, seating and controls
- Insulated cabin
- Fire-retardant materials inside the cabin
- Low engine noise
- Low emissions
- Small radius turning circle
- Automatically controlled air suspension Driver's seat
- Adjustable steering column to suit most operators and conditions
- Ergonomically designed cabin controls and cabin interior
- Cabin complies with the Australian Vehicle Standards Rules 1999
- Cabin is mounted on isolating airbags to minimise the road vibrations
- All cabins are fitted with air-conditioning and an approved intergraded sleeper berth
- Daily inspection check points are easily accessed behind the front hatch panel and around the cabin
- Parabolic front springs to enhance the ride qualities of the vehicle, and minimises fatigue
- The UD Trucks New Quon range is designed for engine power up to 460Hp

Technical data for the vehicle or additional fitted modification specifications are available on request from your local UD Trucks Dealership.

Incidents related to Drivers operating heavy vehicles shows the following common causes of injury are:

- Driver falling from heights
- Mechanical or system failure
- Impact or collision during transit
- Sprains and strains
- Hand injuries
- Exposure to hot surfaces resulting in burns
- Contact with fuel, AdBlue, oil and coolant



## UD Trucks Compliance

UD Trucks are built in accordance with current Australian Design Rules (ADR) 3<sup>rd</sup> Edition and conform with all requirements of the Department of Infrastructure and Transport. This information is available on the web sites listed below.

- [www.infrastructure.gov.au/roads/motor/design/adr\\_online.aspx](http://www.infrastructure.gov.au/roads/motor/design/adr_online.aspx)
- [www.infrastructure.gov.au/roads/vehicle\\_regulation/bulletin/vsb\\_06.aspx](http://www.infrastructure.gov.au/roads/vehicle_regulation/bulletin/vsb_06.aspx)

The risk assessment is limited to the following elements with the life of the vehicle:

- Daily Vehicle Checks
- Maintenance Access
- Driving the Vehicle

The risk assessment is limited to the actions and areas of exposure for the Driver, it does not cover:

- Servicing and maintenance tasks completed by UD Trucks Technicians
- Operation of bodies, attachments or ancillary equipment fitted by third party suppliers

UD Trucks emphasise that the vehicle must not be used in any of the following conditions:

- Driving on road surfaces unsuitable for the vehicle or its combination
- Operating above rated axle load limits or GVM specified by UD Trucks
- Outside the operating limits as deemed by Local, State/Territory and National Regulations

The vehicle is subject to scheduled service intervals recommended by UD Trucks along with safety roadworthy compliance inspections as detailed in state, territory and national regulation or applicable accreditation schemes.

## Risk Management

The risk management review has been conducted in accordance with the Australian Standard titled AS NZS ISO 31000-2009 Risk management - Principles and guidelines in which the severity and the consequence of the incident are rated in the following matrix.

### Rating the Risk

Risk Rating is calculated by multiplying the likelihood against the consequences, e.g. taking a likelihood of 4, which is classified as Likely, and multiplying this against a consequence of 2, which is classified as a Minor Injury 1st aid required, would give you an overall risk rating of 8, which would be risk rated as a low risk.

- Extreme Risk = 20 to 25.
  - Extreme risk activities MUST not attempt task.
- High Risk = 9 to 16.
  - High Risks activities should cease immediately until further control measures to mitigate the risk are introduced.



- Medium Risk = 5 to 8.
  - Medium Risks should only be tolerated for the short-term and then only whilst further control measures to mitigate the risk are being planned and introduced, within a defined time period.
  - Note: Medium risks can be an organisations greatest risk (its weakness) due to the fact it can be tolerated in the short-term.
- Low risk equals 1 to 4.
  - Low Risks are largely acceptable, subject to reviews periodically, or after significant change etc.

**Assess the Level of Risk**

Consider the hazards identified and use the risk assessment matrix below as a guide to assess the risk level.

Likelihood	Consequence				
	1. Insignificant	2. Minor	3. Moderate	4. Major	5. Critical
5. Almost Certain	Medium	Medium	High	Extreme	Extreme
4. Likely	Low	Medium	High	High	Extreme
3. Possible	Low	Medium	High	High	High
2. Unlikely	Low	Low	Medium	Medium	High
1. Rare	Low	Low	Low	Low	Medium

Consequence	Description of Consequence	Likelihood	Description of Likelihood
1. Insignificant	No treatment required	1. Rare	Will only occur in exceptional circumstances
2. Minor	Minor injury requiring First Aid treatment (e.g. minor cuts, bruises, bumps)	2. Unlikely	Not likely to occur within the foreseeable future, or within the project lifecycle
3. Moderate	Injury requiring medical treatment or lost time	3. Possible	May occur within the foreseeable future, or within the project lifecycle
4. Major	Serious injury (injuries) requiring specialist medical treatment or hospitalisation	4. Likely	Likely to occur within the foreseeable future, or within the project lifecycle
5. Critical	Loss of life, permanent disability or multiple serious injuries	5. Almost Certain	Almost certain to occur within the foreseeable future or within the project lifecycle

Assessed Level	Risk	Description of Risk Level	Actions
<input type="checkbox"/>	Low	If an incident were to occur, there would be little likelihood that an injury would result.	Undertake the activity with the existing controls in place.
<input type="checkbox"/>	Medium	If an incident were to occur, there would be some chance that an injury requiring First Aid would result.	Additional controls may be needed.
<input type="checkbox"/>	High	If an incident were to occur, it would be likely that an injury requiring medical treatment would result.	Controls will need to be in place before the activity is undertaken.
<input type="checkbox"/>	Extreme	If an incident were to occur, it would be likely that a permanent, debilitating injury or death would result.	Consider alternatives to doing the activity. Significant control measures will need to be implemented to ensure safety.

**Risk Assessment Matrix Guide UD Trucks New Quon Primemover and Rigid**

Ref No	Hazard Identified	L	C	Score	Risk	Risk Control Measures	Risk Reduction Measures	L	C	Score
1	Vehicle fluid level checks	4	3	12	Over filling of the fluids and causing damage to the vehicle, injury to persons and contamination to the Environment.	Use Vehicle fluid level inspections points. These points are easy to access from the ground to eliminate Operators climbing around the vehicle at height. Engine Oil can be checked through the Driver information display to eliminate oil spills and the requirement of rags/wipes used.	The engine is to be cool. Most fluids are visible through transparent reservoirs, engine has a dip stick for checking oil fluid levels, or oil fluid levels can be checked through engine management system. Refer to Owner's Manual and your Company procedures.	2	3	6
2	Entering and exiting the cabin	4	5	20	Potential for Driver and passenger to slip and fall on entry/exit to cabin.	UD Trucks are fitted with grab handles and steps. The Driver's side steps into the cab are illuminated in the dark to help deliver safe entry into the vehicle at night. Mirrors are fitted to the cabin to assist safe exiting. Drivers should also activate hazard lights.	Non-slip steps fitted to all access areas of the vehicle. Wide opening doors to gain entry/exit of the cabin. Grab handles and steps position to maintain three points of contact when entering/exiting the cabin, large mirrors including wide angle mirrors to check for traffic or pedestrians. Refer to Owner's Manual and with your Company procedures.	1	5	5
3	Driver's Seat, steering wheel and control adjustments	4	5	20	Poor driving posture, potential muscle fatigue and/or back injuries. Not having full control of the brake pedal and accelerator. Possible loss of control causing death or serve injury.	Fully adjustable Driver's seat with lumbar support and auto height levelling, retractable seat belts with an audible alert (if not worn) and adjustable slide to allow for reach and full control of the brake and accelerator pedals. Steering wheel can be adjusted to suit individual Drivers of various build stature.	Seat adjustments are designed for maximum comfort and vehicle control. The cabin has been ergonomically designed so the Driver can access all switches from the seated position. ALWAYS wear a seat belt and make sure the vehicle is stopped when adjusting the seat, steering column/wheel. Refer to Owner's Manual.	1	5	5
4	Parking Brake application	3	5	15	Truck rolling away, potential to cause injury, death and/or property damage.	Park brake safety alerts are visual warning lights in the Driver information display.	In addition, an audible warning sounds when door is opened when the park brake is not engaged whilst in gear. Refer to Owner's Manual and your Company procedures.	1	5	5
5	Harsh Braking	3	5	15	Potential to lose control and cause injury, death and/or property damage.	ABS (Anti-lock Braking System): An electronically controlled system monitoring all axles on the truck and the trailer maybe equipped with ABS. EBS (Electronically controlled Brake System): An advanced combination of an electronically controlled system and conventional air brakes. UDSC (UD Stability Control): An advanced electronically controlled system utilising ABS, EBS and several other systems on the truck, to maintain stability. ASR (Anti Slip Reduction): Will detect and eliminate wheel spin by reducing engine torque or applying a wheel brake.	These available features monitor the vehicle at all times and counteracts the forces during possible loss of control, through the truck's electronic brake system, engine management system and retarder, and the trailer's braking system (if fitted with compatible ESP systems). The UDSC system helps to avoid accidents in the event of sudden and unexpected manoeuvres. Vehicle are fitted with Traffic Eye Brake that activates a visual and audible alarm and engages the trucks brakes when gap between the truck and the vehicle in front is too close while traveling. The Driver may need to take evasive action. Refer to the Owner's Manual.	1	4	4

**Note:** The New Quon has a comprehensive suite of active & passive safety features included as standard sold within Australia. Other safety items or equipment are optional. Be aware that connecting of non-ABS or EBS equipped trailers to the New Quon will result in some, or all of these new safety features being deactivated or restricted.

Consult your trailer manufacturer regarding your trailers capabilities & specifications. Please consult your UD Trucks Dealership.

Ref No	Hazard Identified	L	C	Score	Risk	Risk Control Measures	Risk Reduction Measures	L	C	Score
6	Replacement parts	4	5	20	The use of non-genuine parts may cause premature wear or damage to the vehicle, cause vehicle failure & void warranty.	UD Trucks only recommend the use of Genuine Parts and Accessories.	UD Trucks only warrant the use of genuine parts. All UD Trucks are tested to the ADR standards using only genuine parts. The use of non-genuine parts may affect ADR compliance and warranty. Refer to the Owner's Manual.	1	5	5
7	Transmission operation	2	5	10	Potential to cause damage to vehicle, lose control and cause an incident resulting in an injury and/or death and property damage.	All UD New Quon models are fitted with the ESCOT-VI automated transmission. A safety lockout feature is fitted so the engine will NOT start in gear, it must be in Neutral (N) to start.	UD Trucks have comprehensive information with driving instructions on the Automated Transmissions found in the Owner's Manual. UD Trucks offer Customers Product and Driver Training on request or refer to the Owner's Manual.	1	5	5
8	Blind spot while driving	4	5	20	Potential to cause injury, death and/or property damage.	Side rear view main mirrors are heated and are remote controlled for adjustment and comply with ADR standards. The convex spotter mirrors can be manually positioned at the bottom of the main mirrors on both sides for improved vision. The passenger side door also has a spotter mirror mounted at the top of the door facing down looking beside the vehicle. An additional mirror is fitted to left hand pillar mounted facing down along the front of the vehicle to identify pedestrians or objects at the front of the vehicle.	Lane Departure Warning System (LDWS) is a system to reduce the risk of accidents, by warning the Driver when a vehicle is detected to be drifting from the lane unintentionally. Extra care must be taken to adjust the mirrors so that you can clearly see traffic or any potential hazards. Mirrors must be clean and in good condition.  The vehicles are fitted with an audible reversing alarm to warn people in the area. The trucks are fitted with a hill start feature to prevent roll back during start off in hilly terrain. UD Trucks offer Customer product training or refer to the Owner's Manual.	1	5	5
9	Battery Electrolyte Level and security	3	4	12	Handling battery corrosive acid, overfilling batteries or exposing batteries to flame/sparks cause a possible explosion resulting in injury, death and /or property and vehicle damage.	Batteries have plastic covers to reduce possibility of arcing. This allows airflow to exhaust any possible build-up of dangerous gases and the batteries are restrained by a suitable clamping bracket. Some models may have batteries fitted to the side of the chassis. Batteries are reliable and low maintenance items.	Ensure when checking batteries that the engine is switched off, the <b>Red or Yellow</b> battery isolator key is off (if equipped) and the vehicle is on level ground. Wear appropriate PPE e.g. safety glasses, gloves, boots and long clothing. Use three points of contact when gaining access if required. <b>Danger:</b> The battery generates flammable hydrogen gas. Do not smoke or allow sparks near the battery. Doing so could cause the battery to ignite and explode causing injury. <b>Only trained persons</b> should be authorised to check batteries or Refer Owner's Manual and your Company procedures.	1	4	4
10	Windscreen cleaning task	4	4	16	Cleaning the windscreen potential to cause injury, falling from heights.	Windscreen wipers are fitted with spray nozzles attached to the wiper arms. The washer fluid is operated by activating the wiper washer button at the end of the lever to aid in cleaning the windscreen whilst on the move or parked.	Vehicles are fitted with tread steps in the bumper bar and grab handles below the windscreen to allow a Driver access to clean the screen while maintaining three points of contact at all times. Clean windscreen with correct cleaning chemicals, read the Safety Data Sheets and wear appropriate PPE. Refer Owner's Manual and your Company procedures.	1	4	4

Ref No	Hazard Identified	L	C	Score	Risk	Risk Control Measures	Risk Reduction Measures	L	C	Score
11	Exhaust System	3	4	12	Contact with exhaust system whilst hot has potential to cause burns & injuries	Muffler is shielded so no direct contact can be made.	Heat shields have warning placards placed on the vehicle to alert Drivers of the potential burn hazards". Refer to Owner's Manual.	1	4	4
12	Draining Air Tanks	3	3	9	Dust into Driver's eyes, Loss of air pressure causing vehicle malfunction.	UD Trucks are fitted with an air drier for removing moisture and contamination. Air tanks have drain valves fitted to activate. These are for draining air and to encourage workshop technicians to check for any contamination at scheduled service intervals.	Automatic filtered air dryer systems eliminate the possibility of any residual moisture left in the vehicles air system. When draining air tanks, use suitable PPE and safety eyewear equipment. The air dryer system is a serviceable item with a filter, this forms part of the scheduled servicing arrangements. Refer to Owner's Manual and your Company procedures.	1	3	3
13	Diesel fuel spill	3	3	9	Spillages could occur when refuelling your vehicle potential to cause personal injuries (fumes) or contamination to the environment.	Large fill point with a lockable cap. Tank has a built-in recess neck to reduce a risk of the fuel tank being over filled.	Care must be taken to prevent fuel spillages. Wear appropriate PPE when handling fuel. Drivers MUST notify appropriate authority/persons if a spill occurs. Use correct fuel as per vehicle manufactures specification or Refer to Owner's Manual and your Company procedures.	1	3	3
14	AdBlue Spill	2	2	4	Spillages could occur when refilling your vehicle potential to cause injuries or contamination to environment.	Smaller fill neck is fitted so diesel pumps cannot cross contaminate and is fitted with a lockable cap. The AdBlue tank has a built-in recess neck to prevent being over filled.	Care must be taken to prevent AdBlue spillages. Wear appropriate PPE when handling AdBlue. Drivers MUST notify appropriate people if a spill occurs. AdBlue is NOT a dangerous goods, and Drivers should be aware of the SDS (Safety Data Sheets) requirements for AdBlue. Refer to Owner's Manual and your Company procedures.	1	2	2
15	Checking Wheel nuts and tyre pressures	3	5	15	Truck wheel detaching and loss of control causing injury or death and Increased fuel usage, possible tyre failure with underinflated tyre pressures.	Tyre placard detailing correct tyre pressure are stamped to on the side wall of the tyre. Drivers should visually check wheel nuts and tyre pressures prior to departure. All tyre manufactures have a Tyre Wear Indicator (TWI) stamped on the tyre for legal tread depth. UD Trucks are supplied with tyre changing tools and instructions how to check and torque the wheel nuts correctly.	Ensure tyre size and tyre air pressure always complies with the vehicle's Owner's Manual. Ensure no objects have become lodged between the dual wheels. Check for dents, loose lugs, rust trails or cracks in the rim assembly. Check nut tension and follow instructions set out in the Owner's Manual and your Company procedures.	1	5	5
16	Driver trapped in cab during a Vehicle Rollover	3	5	15	Potential to cause injury or death and/or property damage.	All cabs strength requirements comply with all ADR Standards. All loose items in the cabin should be restrained including tools, fridges and passengers. UD Trucks are equipped with a rubber seal windscreen to enable an operator to kick the windscreen out and escape through the windscreen opening in the event of a roll over.	The side windows are fitted with toughened safety glass and easily smashed to gain entry or exit during an emergency. Drivers MUST wear the seat belt and ensure there are NO loose items inside the cabin. Refer to Owner's Manual and your Company procedures.	1	5	5

Page 9

Ref No	Hazard Identified	L	C	Score	Risk	Risk Control Measures	Risk Reduction Measures	L	C	Score
17	Wheel changing and handling spare wheel	3	5	15	Injuries may occur to your fingers, hands, shoulders, back, face, eyes. Truck may fall off the jack causing serious injury or death. Tyre may blow while under the vehicle.	Tools are provided for changing flat tyres. Only trained competent people should attempt changing wheels. Wheel spanner and breaker bars are supplied with the vehicle. Guidelines are set out in the Owner's Manual with detailed instructions how and where to place the jack, undo and retention wheel nuts in order, and how to remove and replace the tyre/wheel on to the hub. Refer to Company procedures.	Ensure that the vehicle is parked on flat, level ground and that park brake is applied. Ensure ignition is switched off. If vehicle is parked on a road, ensure hazard and headlights are activated. The safety reflective triangles are positioned correctly. Appropriate PPE must be worn, refer to owner's manual for the correct procedure for tyre changing. Follow guidelines set out in the Owner's Manual and your Company procedures.	1	5	5
18	Driving the vehicle interact with other road users	3	5	15	Potential to cause injury, death and/or property damage	UD Trucks is built to ADR standards. UD Trucks can give you further information regarding Driver training requirements. Vehicle must only be operated by a suitably licenced and or trained Driver and familiar with the safe operation of the vehicle. Comply with road traffic regulations, drive to conditions and follow all fatigue management guidelines. The vehicle is fitted with Front Underrun Protective Devices (FUPDs) to help save lives with frontal impact. This feature has now become standard by the Australia Design Rules ADR standards. UD Trucks are fitted with long-lasting LED low-beam lamps that provide bright, clear light to improve daytime detection and night visibility for safe driving. UD Trucks are fitted with Drivers SRS airbag and seat belt pretensioner.	UD Trucks has various safety features available to help improve on-road safety by: <b>Traffic Eye Brake System</b> - If a risk of collision with a forwarding vehicle is detected, the system sounds an alarm and if the Driver's action is insufficient to avoid a collision, brakes are applied to decelerate the vehicle to avoid a collision significantly reducing the risk of severe injuries. <b>Lane Departure Warning System</b> - Drifting out of lane is a common cause of serious accidents. <b>UD Stability Control</b> - detects conditions in which the truck could become unstable, such as curves or slippery road surfaces, the system applies control appropriate to engine output and braking power to each tyre to maintain stability. <b>Optional Safety Support Feature:</b> <b>Driver Alert Support</b> - Is a camera installed inside the cab facing forward through the windscreen which recognises the positional relationships between traffic lanes and vehicles and estimates Driver awareness based on steering irregularities. If the Driver's concentration drops, a two-step alarm and warning message on the multi-display alert the Driver and suggest a break.	1	5	5
19	Connecting Air Lines/AUX leads/hoses to trailer if using as primemover	3	5	15	Slipping off rear of truck. Potential to cause personal injury/death.	Exhaust systems has been shielded to protect the Driver from heat exposure.	Extra care must be taken when climbing up and down when connecting air lines. Always use three points of contact, correct footwear on and suitable PPE must be worn. Lighting has been positioned to the rear of the cabin for dark situations. Refer to Owner's Manual and your Company policy or procedures.	1	5	5
20	Raising and lowering the cabin	4	5	20	Injuries may occur to your hands, fingers, shoulders, back and potential death.	Electric cabin tilt system can be operated from the ground. When the cabin is completely tilted (over centres) it cannot be lowered to cause a crush situation. When the cabin is lowered, it is automatically locked into place, an audible and visual warning alarm will activate if not properly locked down into position.	Ensure the vehicle is parked on level ground BEFORE tilting cab. Ensure loose items are removed from cab. If a bull bar is fitted, ensure it is lowered. Ensure there is sufficient clearance in front of and above the cabin before tilting, and ensure doors are closed with no one in the cabin. DO NOT tilt cabin under power lines. Prior to operating the cab tilt system, read Owner's Manual and comply with your Company procedures.	1	5	5

## Vehicle Risk Assessment

**Note:** This Risk Assessment is for UD Trucks product only. This Risk Assessment does not cover any other specialised equipment fitted to the chassis or cabin. Including, but not limited to, the below listed items.

- vehicle body
- bull bars
- non-genuine roof spoilers or air kits
- fifth wheels (turntables) or trailer couplings
- modified wheels or tyres that are different from the specified units fitted as standard
- specialised plant or auxiliary equipment mounted to the chassis cabin. (This would require a risk assessment to be supplied from the manufacturer of the specialised auxiliary equipment).

**UD Trucks is not responsible for any modifications or alterations.**

## Legal Requirements Owners/Drivers

It is the Owners and or Drivers Responsibility that:

- The Driver needs to obtain a suitable class licence for this vehicle or combination (if travelling on public gazetted road networks) or be trained to operate the vehicle on private land holdings
- The Driver is not affected by alcohol or drugs, unless the drugs are prescription medication cleared by a doctor to drive the vehicle
- The Driver is wearing a seat belt as required by law in all States and Territories
- The Driver has the correct safety clothing and PPE as required by WHS
- The vehicle must be registered and roadworthy
- The Driver must comply with State and Territory regulations, road and traffic laws and use a work diary when required
- The Driver must be aware of their responsibilities and duties as a Driver
- The owner ensures the Driver is familiarised and trained in the vehicle they will be operating.

**UD Trucks can offer Owners and Drivers Product Training and support.**

## Operator Daily Pre-Departure Checks

### Access Behind the Front Bonnet

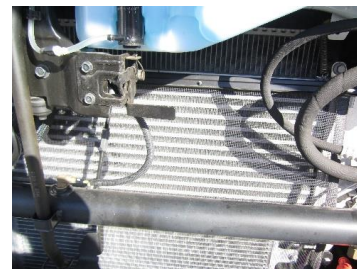

Open the front bonnet assembly by:

- Pulling the Bonnet lever situated on the Driver's side near the accelerator pedal
- Reach in behind the centre of the grill and locate the secondary safety latch and pull towards the front of the vehicle
- The bonnet will now open outwards from the bottom
- Engine oil level may be checked without the bonnet opened
- Only add recommended engine oil when the level has reached the add marker on the bottom of the dip stick, refer to the Owner's Manual
- Engine Oil filler cap is marked located to the right of the dip stick beside the cab suspension



- Check windscreen wash fluid transparent reservoir tank situated behind the bonnet
- Check tyres for worn tread, cuts, under inflation, valve stem positions, dual tyres not touching, and for any items lodged between dual tyres e.g. rocks, mud or sticks etc.
- Check rims for dents in flanges, loose inner valve extensions, wheel nuts and rust trails or cracks in rim mounting areas
- Check all electrical - headlights high /low beam, indicators left/right, stop lights, side marker lights, park lights, driving /fog lights etc.
- Check vehicle body - for damage, load security, cabin entry grab handles, cabin steps, doors and window operation, curtains & straps, mirrors, windscreen secure & free of damage or cracks and clean, air tanks, fuel tanks, tool boxes, fluid leaks, vehicle posture, number plates, rear reflective markings and warning triangles, etc.
- Inform your supervisor or workshop if the vehicle requires regular top ups.

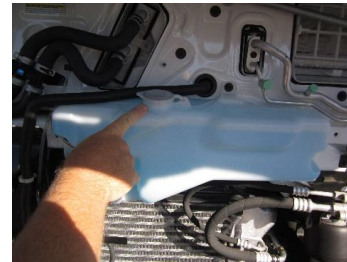

Additional Fluid checks to the rear of the cabin left side

- Only add engine coolant when engine is cool through the transparent reservoir tank (maximum/minimum marks). Do not mix coolant brands Refer to the Owner's Manual



- Power steer fluid reservoir is located beside the Coolant reservoir and has a maximum/minimum level marked on the tank
- **Do Not over fill any fluid levels on the vehicle.**

**Battery Position**

Batteries security and the cover is in place and secured.



Batteries can be mounted in various places depending on vehicle spec, configuration and application.



### Entering and Exiting the Vehicle

- Park the vehicle in such a way to ensure there is sufficient room to fully open the Driver's and/or Passenger's door (if required)
- Approach the vehicle's door by the safest route. Check for traffic flow or any interference or hazards before entering or exiting the vehicle
- Use entry/exit steps and body grab handles to climb into and out of the vehicle, maintaining three points of contact at all times
- Steps are hole stamped tread plates designed to allow:
  - Maximum grip and allows mud and dirt to fall through holes
  - Prevents build-up of mud and dirt for maximum traction
  - Shielded to prevent foot slipping off step
- Adjust the seat to required position to enable control of vehicle's pedals (accelerator and brake pedal), then adjust the steering column by lifting the steering column lock/handle and adjust the wheel to suit the Driver and have sufficient vision to monitor all gauges in the vehicle's information display
- All adjustments should only be made when the park brake is applied, transmission in neutral and you are sitting in the Driver's seat
- All adjustments should be made to maximise the Driver's comfort and to reduce the risk of fatigue
- **Most injuries occur entering and exiting the cabin.**

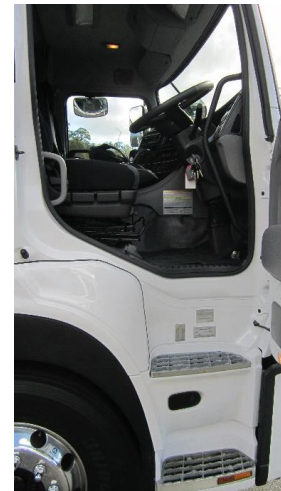

**REMEMBER: Always, Wear your Seat Belt!**



### Parking Brake and Transmission

- The transmission shifter is located beside the Driver's seat and easily reached by the Driver's hand and is in a prime position to reduce Driver fatigue



#### Parking brake

- The park brake is operated by a lever beside the Driver's seat. The park brake is manually engaged by pulling the lever up past its point of resistance. When the park brake is engaged, the red warning light will appear in the information display panel.
- To disengage the park brake, pull the locking sleeve out towards the lever and lower the lever into the off position. The park brake light in the Driver information display will disappear.
- An audible alarm will sound if the park brake is disengaged and the door is open with the vehicle left in gear.
- All controls for the vehicle including parking brake, transmission shifter, air conditioning, and switches are located within easy reach of the Driver.
- All instrumentation details and symbols comply with the International standards and specifications worldwide.



**Note:** UD Trucks has accredited Driver Product Trainers to offer owners and Drivers training with vehicle familiarisation on request. The cabin is designed to suit the latest ergonomics for the Drivers.

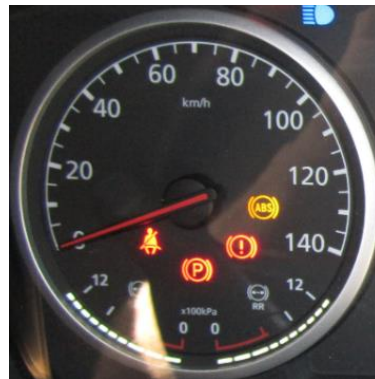

1. Easy-to-read font size, easy-to-see symbols and gauges.
2. Multi-display, controlled with switches on the steering wheel.
3. Classy design featuring silver rings.
4. Sub-display
5. Cruise Control information
6. Gear number information
7. Auxiliary brake information

**Checks Prior to Exiting**

- Ensure transmission is in neutral
- Check the park brake is applied
- Check for traffic (by mirror or visual check) before opening door
- Lower the door window when in windy conditions
- Exit the vehicle backwards by using available steps and grab handles while at all times maintaining three points of contact (do not jump)
- Close the door
- UD Trucks have integrated these safety features to assist with safe entering and exiting.

**“Three Points of Contact” to enter and exit vehicle**

### Seat Adjustments

1. Lumbar support adjustment
2. Seatback angle adjustment
3. Seat base tilt (raise and lower the rear)
4. Seat base tilt (raise and lower the front)
5. Damping adjustment (soft or hard)
6. Seat sliding adjustment (backwards and forwards)
7. Seat suspension lockout lever
8. Seat base cushion adjustment (backwards and forwards)
9. Armrest

The Driver's seat is an air suspended seat, is has:

- Auto height levelling
- Multiple adjustments and functions



- Air suspended seat
- Damper adjusting lever
- Forward/ Rearward adjustment lever
- Seat suspension lock lever

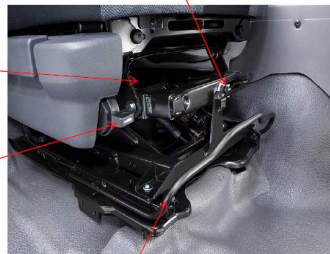

### Interior

- Interior lighting working
- Checks inside the cabin
- Instruments / cluster are functioning
- Check- mirrors, seat position, door locks and windows are operational

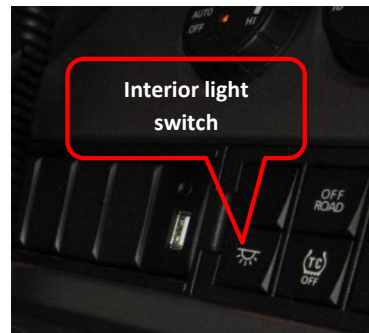

### Interior Checks Continue

- Check- Seat belt condition and operation
- Check- Controls are working correctly
- Check- Windscreen for cracks and damage
- Check- That all loose items has been secured
  - **Heavy items should never be carried in the cab or stored unsecured**
- Remember to always familiarise yourself with the vehicle / controls if it is your first time that you are driving the vehicle
- Report any faults of if you do not feel confident with your knowledge with the vehicle or controls notify to your supervisor / manager
- Before starting the engine ensure the park brake is applied and the transmission is in neutral.

### Exterior Mirrors

- Electronically controlled and heated
  - No need to scrape ice or moisture off the mirrors

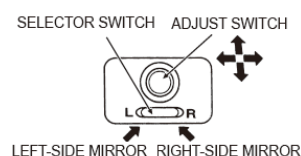

#### Power mirror switch

Push either side of the selector switch to select the rear-view mirror to be adjusted and then move the adjust switch up or down, left or right to adjust the view to the rear.

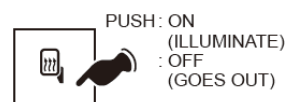

#### Mirror heater switch

Turning this switch ON activates the heaters in the mirrors (right and left rear-view mirrors) to clear the fogged mirrors. The switch illuminates in amber while the heater is activated. The heater will turn off automatically in 60 minutes, however, be sure to turn the switch OFF and confirm that the amber switch illumination has gone out after use.

### Checks After Start-Up

- Check – Engine oil pressure is OK and there are no other alerts active
- Check – Fuel and AdBlue fluid levels are OK
- Check – Air pressure is OK
- Check – Gauges and meters are working correctly
- Check – Trailer couplings and all auxiliary fittings
- Check – Brake operation (apply foot brake and trailer brake separately at low speed prior to leaving your premises)
- Check – Lights and Indicators
- Check – Horn and instruments, windscreen, washers, wipers, demisters
- Check – For fluid leaks e.g. oil, fuel, AdBlue and coolant

- Check – That there are safety triangles. Safety triangles (Break down triangles) are conveniently located and in easily for the Driver to obtain. Triangles must be used in accordance with State and Territory Regulations road and traffic laws
- All checks to be performed with reference to the Owner’s Manual and to the Company’s Procedure
- Report any faults to your supervisor/manager
- The exhaust system is fully shielded to reduce risk of injury
- Vehicle fluid levels checks (Fuel Tank diesel fuel and AdBlue Tank)

Link to AdBlue Safety Data Sheet: [https://www.bp.com/content/dam/bp-country/en\\_au/products-services/fuels/adblue/MSDS%20Adblue.pdf](https://www.bp.com/content/dam/bp-country/en_au/products-services/fuels/adblue/MSDS%20Adblue.pdf)

Link to diesel Safety Data sheet: <http://www.msds.bp.com.au/msds.aspx?msdsno=0002790-AU>

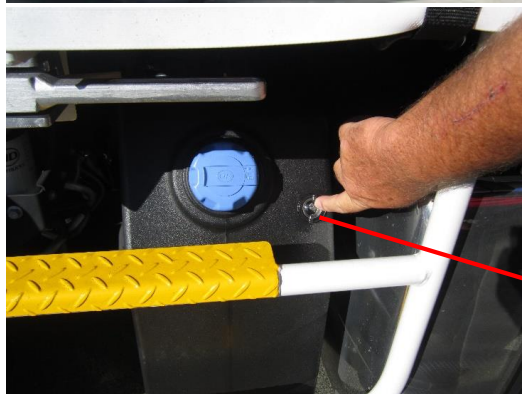

Lockable cap and fill sight window on the Adblue tank

When filling tanks, do not over fill and contain any spillages and refer to your Company’s procedure.

### Entry and Exit Access to Chassis



Sample of optional features shown from a Dealership with the primemover's air supply lines, taps and electrical leads set up with a catwalk tread plate.

Operator injuries may occur during entering and exiting the chassis.

- Approach the vehicle by the safest route
- Check for traffic before climbing onto or off the vehicle and use an aide e.g. step ladder or platform to help gain access
- Ensure that there is enough room to conduct task
- Airlines and electrical leads connected and secured to and from the trailer.

Refer to Company policy for correct connection of airlines and auxiliary electrical cables/leads.



### Checks While Driving

Continuing checks while driving means safe driving habits:

- Always wear a seat belt
- Check steering feels normal
- Check auxiliary brake (exhaust/engine brake operation) operation
- Check the brakes are working correctly
- Regularly monitor the instrument panel for any warning lights and listen for audible alerts
- Ensure air tanks gauges maintain normal range
- Always obey speed limits and traffic regulations
- And always follow a fatigue management plan
- Use the steps and grab handles when cleaning the windscreen



**Footsteps inserted above the bumper bar and grab handles below the windscreen enable an Operator to use three points of contact while cleaning the windscreen.**

### Additional Features and Information

#### Cab Tilt

- Park brake applied
- Transmission is in neutral
- Doors are closed
- Lower bull bar (if equipped)
- Front bonnet is opened
- Ensure all loose items are removed from the cabin
- Ensure no one is in the sleeper berth
- Check above for power lines or obstacles and in front of the vehicle to ensure there is sufficient room to tilt the cabin
- Follow the instruction in the Owner's Manual
- All vehicles have an electrical override system for the cabin tilt, refer to Owner's Manual for details.





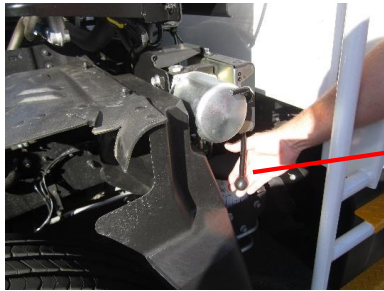

Electric cab tilting lever



- Cab tilting lever



Cab tilt directional lever

**Check Points**

- Cabin filter can be accessed for cleaning when the grill is open
- Easy access to bulbs can be done with the cabin up

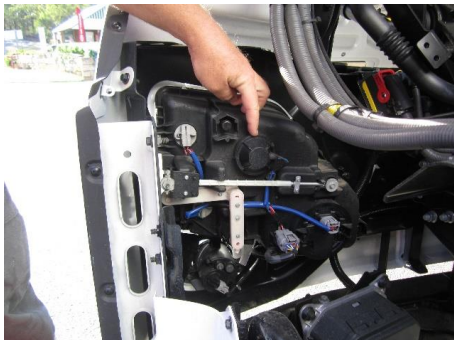

Pull the cabin filter outwards to clean or replace

- UD Trucks are fitted with an air drier to remove moisture, contamination and any foreign particles from the air system. It is recommended to manually drain the air tanks daily

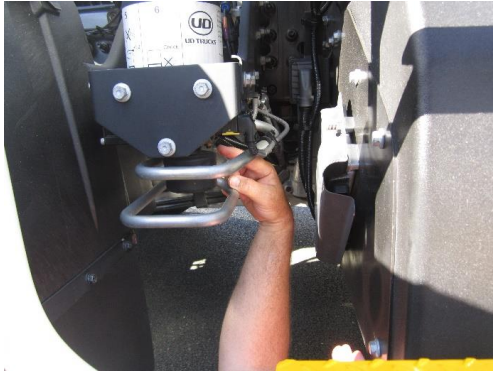

- Fuse and relay location and replacement guide

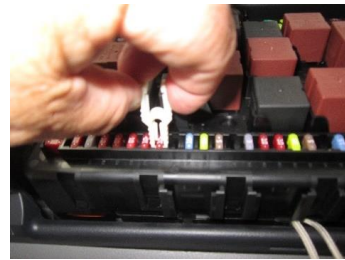

### Responsibilities of the Owner/Driver

The Owner/Driver are responsible for ensuring that:

- The vehicle is serviced and maintained in accordance with UD Trucks warranty and service schedule
- Daily checks are carried out by the Driver
- If any faults, problems or failures occur they must be reported to the owner/supervisor or as per company policy/procedure and chain of responsibility requirements
- If any fault is found, and deemed a warrantable fault, the vehicle must be presented at an authorised UD Trucks dealer immediately
- If any fault is found to have caused an incident in which there has been a death or serious injury or illness of any person, UD Trucks must be notified immediately
- UD Trucks must comply with the Australian Standards and fitted with genuine or approved genuine manufactured parts therefore, can only warrant the use of genuine parts for any repair.

### Guidelines and Legislation

UD Trucks chassis-cab is manufactured and designed to comply with all applicable Australia Design Rules (ADR) at the time of manufacture. ADR compliance of the cab chassis manufactured by UD Trucks is granted by the Department of Infrastructure and Transport. Proof of compliance of an individual chassis is shown by a fitment of an ADR Identification (compliance plate).

Various regulations relating to the vehicle performance, equipment and safety have been issued by government organisations. These regulations include but are not limited to the Department of Infrastructure and Transport regulations. Other Federal, State, Territory and local regulations may also apply.

Second-Stage-of-Manufacturer (SSMM), body builders and motor carriers are responsible for knowing and complying with all regulations that may apply to the vehicle. A finished vehicle may also require devices that are not specified in the regulations. SSMM, body builders and motor carriers must determine what safety devices are necessary for the safe operation of the vehicle.

**QUOTATION PREPARED FOR THE:**



---

**DAIMLER TRUCKS PERTH**

---



PATRICK KENDREW  
PHONE: 08 9311 7400  
MOBILE: 0429927257  
EMAIL: [pkendrew@vvgtruck.com.au](mailto:pkendrew@vvgtruck.com.au)



Mailing Address PO Box 1914 Midland DC WA 6936

Mercedes-Benz - are registered trademarks of Daimler AG, Stuttgart, Germany  
Freightliner is a registered trademark of Freightliner LLC, USA  
Fuso is a registered trademark of Mitsubishi Fuso Trucks & Bus Corporation, Japan

4 Ulm Place  
Perth Airport WA 6105  
Tel+618 9311 7400  
[www.daimlertruckspertth.com.au](http://www.daimlertruckspertth.com.au)  
[enquiries@daimlertruckspertth.com.au](mailto:enquiries@daimlertruckspertth.com.au)

**Ref: 30644**

10<sup>th</sup> October 2023

Sarah Caporn  
Executive Manager of Works and Services  
Shire of Quairading  
10 Jennaberring Road  
QUAIRADING WA 6383

**RE: RFT 01/2023 SUPPLY OF TWO (2) 6-WHEELER TWO-WAY TIPPING TRUCK**

Dear Sarah,

---

Thank you for the opportunity to supply our tender along with details to supply Two(2) only **2023/24 FUSO FV70 SHOGUN 6x4** cab/chassis fitted with Two Way Tipper Body set up and ancillary equipment to the **SHIRE OF QUAIRADING** requirements.

For any further details that may be required, please refer to the enclosed specification sheet, or contact the undersigned who will gladly assist.

Yours faithfully  
**DAIMLER TRUCKS PERTH**



**PATRICK KENDREW**  
GOVERNMENT/SHIRE SALES CONSULTANT



**MIKE ALLEN**  
NEW FUSO TRUCK SALES MANAGER



Mailing Address PO Box 1914 Midland DC WA 6936

Mercedes-Benz - are registered trademarks of Daimler AG, Stuttgart, Germany  
Freightliner is a registered trademark of Freightliner LLC, USA  
Fuso is a registered trademark of Mitsubishi Fuso Trucks & Bus Corporation, Japan

4 Ulm Place  
Perth Airport WA 6105  
Tel +618 9311 7400  
[www.daimlertrucksperth.com.au](http://www.daimlertrucksperth.com.au)  
[enquiries@daimlertrucksperth.com.au](mailto:enquiries@daimlertrucksperth.com.au)

<b>SHOGUN SERIES FUSO FV70HK2VFAA MWB 395hp AMT 6x4</b>	
<b>AXLE FRONT:</b>	Reverse Elliot 'I' beam. Load rating 6,500 kg.
<b>AXLE REAR:</b>	Mitsubishi Full Floating Hypoid. Tandem drive with inter axle diff lock. Capacity 21,600kg. Ratio 4.625:1
<b>BRAKES:</b>	Full Air dual circuit, Taper Roller, ABS with ASR. Rear wheel spring actuated park brake. Constant throttle brake, 3 levels of retardation. Trailer hand control valve and air lines.
<b>CAB:</b>	All steel forward control 2 seat electric / hydraulic tilt cab. Air suspended front and rear. Heated & Electric external mirrors both sides. Rear Quarter glass windows, LHS Transom door window. Fluoro interior reading lamp, Cruise Control, Keyless locking, power windows, Air Conditioner, Heater, Demister, cup holders. Driver's Airbag & Seat Belt pre-tensioners. Driver's ISRI Air Suspension seat. Dash and centre console storage areas. Overhead storage pocket with lid, RH door storage pocket. Colour info display for fuel consumption, service indicators, hour meter & Oil level check. ADR42/04 Approved sleeping berth. <u>Multi Media Package:</u> 6.1 LCD in dash touch screen with Bluetooth hands free. CD/DVD player with Digital DAB+ Radio. USB iPod port & Aux satellite Navigation with 3year free maps updates. Three reverse Camera compatible. (Cameras not included).
<b>CHASSIS:</b>	Parallel channel. Tensile strength 540mpa. Width 840mm. FUPS. Wheelbase 4300mm. Clear chassis rail, no top rivets.
<b>CLUTCH:</b>	Automated manual, no clutch pedal, single dry plate Fuso K4/430.
<b>ELECTRICAL:</b>	24V neg. earth. Alternator output: 24V-100amp. Halogen High Beam headlamps, Low Beam LED 24V Acc power outlet. 2x12v 150Ah / 20hr batteries. Reverse buzzer.
<b>ENGINE:</b>	Mitsubishi FUSO OM470-T2 Diesel (ADR 80/03 - Euro VI) 10.7 litre, 6cyl In-line OHV. Waste-gate turbocharged / air to air intercooler. SCR after treatment system. Power / 290kw (395hp) @ 1600rpm. Torque: 2000Nm @ 1100. Water cooled with viscous coupling fan.
<b>FUEL:</b>	Rectangle alloy tank 400 litres with locking cap. 60 litres Ad-blue tank with locking cap. Filter with water separator and dash indicator.
<b>STEERING:</b>	Integral Power Assisted Ball and Nut, tilt/telescopic adjustable.
<b>SERVICE:</b>	50,000 kms service intervals.
<b>SUSPENSION FRONT:</b>	Long taper leaf with double acting shock absorbers.
<b>SUSPENSION REAR:</b>	Long taper leave / 6 rod trunnion suspension.
<b>TRANSMISSION:</b>	Fuso G230-12, 12 Speed automated transmission with auto and manual modes. <b>PTO openings, rear of transmission.</b>
<b>WHEELS AND TYRES:</b>	Single piece Alloy disc 10 stud rims 335mm PCD. (11 off) 22.5x8.25DC with 295/80R22.5 front tyres / 11R22.5 rear tyres.
<b>GVM / GCM:</b>	25,400kg / 53,000kg

---

<b>BODY DETAILS:</b>	Body as described , built to your specifications & manufactured by <b><u>Bruce Rock Engineering</u></b>
	<b>NOTE:</b> Please refer to our nominated body builders quotation attached, for your information as to construction details.
<b>LICENSING:</b>	Daimler Trucks Perth would licence the vehicle on behalf of the Shire as requested. These licensing costs are <b><u>NOT INCLUDED</u></b> in our quotation and would be invoiced separately.
<b>DELIVERY:</b>	To be confirmed at the time of approval
<b>WARRANTY:</b>	Factory Standard five (5) year or 500,000km (whichever occurs first) warranty to the cab/chassis – Bumper to Bumper
<b>TRAINING:</b>	Full training and induction included.
<b>FUEL ECONOMY</b>	Fuso unable to supply due to many variables effecting fuel consumption.
<b>SERVICING:</b>	50,000km or 12 Month Service Intervals
<b>PAYMENT:</b>	Cash on delivery.
<b>NOTE:</b>	Prices are based on manufacturer's prices at the <b>quotation</b> closing date and are subject to <b>CURRENT RULING PRICES</b> or stock available at the quoted price.
<b>24HR ROADSIDE ASSIST</b>	National roadside assist covers Fuso clients for the life of their vehicle from delivery. (Conditions apply) Daimler Trucks Perth for more details
<b>MAIN WORKSHOP</b>	Daimler Trucks Perth Service Centre operates from 8am to Midnight Monday through Friday and Saturday morning where prior arrangements have been made.

**SHOGUN SERIES FUSO FV70HK2VFAA MWB 395hp AMT 6x4.**

<b>PRICE:</b>	List Price	<b>\$ 217,082.86</b>
	Less Fuso Shire Allowance	-\$ 26,596.85
	2023/24 Plated Cab Chassis Only	<b>\$ 190,486.01</b>

**Cab Chassis Standard Specifications**

- GVM 25,400kg
- GCM 53,000kg
- 4300mm wheelbase
- 290kw/ 395hp / 2000nm
- 400 Litre capacity aluminium tank with lockable fuel cap
- 12 speed constant mesh Automatic Manual Transmission (AMT)
- Driver controlled inter-axle lock and cross locks on both axles (LSD option included)
- Rear wheel spring actuated park brake
- ABS plus EBD (Electronic Brake force Distribution)
- 295/80R22.5 (steer) and 11R22.5 (drive)
- Electro-hydraulic cab tilt
- Driver airbag
- Fully integrated auto control air-conditioning
- Electric windows and mirrors
- Radio multimedia unit with LCD touch screen and Bluetooth
- Cruise Control
- Central locking with remote keyless entry
- Adaptative cruise control , lane departure warning, emergency brake warning and stability control
- Drivers air suspension seat
- Fuso toolkit for wheel changes
- Euro IV Standard
- Fuso Telematics now available with free 12-month subscription

**11M3 Tipper Configuration Body & Accessories**

- 4.5m 2.45m x 1.0m Hardox Rear and Side Tipping Body
- Manufactured by Bruce Rock Engineering (Quote attached with proposal)
- PTO switch in cab with programming - Please note PTO off Transmission not Engine
- Spare tyre carrier winch type to headboard incudes spare tyre and rim
- Razer concertina mesh tarp electrically switched with handheld remote
- Lockable battery isolator
- Ski bar on truck cab fitted with two (2) Narva 85246A LED beacons
- 80 channel two-way radio
- Window tinting
- H/D Canvas seat covers and H/D rubber floor mats
- Weather shield fitted to drivers side window
- Pit pass and weigh bridge documents
- Delivery to Shire of Quairading with Handover

	<b><u>Body &amp; Accessories Total</u></b>	<b>\$ 102,527.74</b>
<b>PRICE</b>	<u>Sub Total</u>	<b>\$ 293,013.75</b>
	GST	29,301.38
	<b><u>TOTAL FOR ONE</u></b>	<b>\$ 322,315.13</b>
	<b><u>TOTAL FOR TWO</u></b>	<b>\$ 644,630.26</b>
<b>STAMP DUTY:</b>		EXCEMPT



**LICENSING :** INVOICED SEPERATE

AT COST

**TRADE IN:**

1. Used UD 2013 Tipper - VIN – JNBCWB5EL00L00480  
Rego Q-272 – 192,000kms  
**TRADE IN VALUE Including GST** **\$ 110,000.00**
  
2. Used UD 2012 Tipper - VIN – JNBGWB4DL00H00724  
Rego Q-5122 – 265,000kms  
**TRADE IN VALUE Including GST** **\$ 100,000.00**



SPECIALISTS IN  
ROAD TRANSPORT  
EQUIPMENT

DESIGN + MANUFACTURING

**Date** 05/10/23

**Trading Name** Daimler Trucks Perth

**Address** 4 Ulm Place  
Perth Airport WA 6105

**Contact person** Patrick Kendrew

**Phone** 0893117400

**Job details**

To design, construct and supply one 11m<sup>3</sup> side and rear tip body to suit 6x4 rigid truck chassis with the following equipment and features

- 4.5m X 2.45m x 1.0m body
- 5.0mm Hardox 450 floor
- 5.0mm Hardox 450 side, door, tail gate and front wall
- Side swing (dual) tail gate with air operated lock
- Modify Existing Hydraulic System for Side Tip
- 31Ton under body hoist
- Relocate Hydraulic Tank to Walkway
- All valves etc. fitted to allow for complete body and dog trailer
- Cab mounted remote electrical switching for side door, rear door, body tip and trailer tip operation, Audible limit alert on side tip function
- services to rear with air, electrical and hydraulic couplings
- 6 bolt 22-ton Cushion Hitch Plate Pintle Hook

**HEAD OFFICE & MANUFACTURING**

15 Swan St Bruce Rock WA 6418  
**P:** +61 (0)8 9061 1253  
**F:** +61 (0)8 9061 1188  
**E:** admin@brucerockengineering.com.au

**PERTH**

247 Berkshire Rd Forresterfield WA 6058  
**P:** +61 (0)8 9454 7177  
**E:** admin.perth@brucerockengineering.com.au

**PORT HEDLAND**

47 Phosphorus St Wedgefield WA 6721  
 PO Box 2358, South Hedland WA 6722  
**P:** +61 (0)8 9140 1100  
**E:** admin.ph@brucerockengineering.com.au

BRUCEROCKENGINEERING.COM.AU

ABN 36 735 814 571 MVR Licence MRB 6163

- Supply rated Towing crossmember to specification
- 1m long tray behind cab, Toolbox, Water Tank Tyre Carrier winch type
- Abrasive blasted to class 2.5, epoxy primed and two pack top coated in your colors
- Rope rails and Shovel rack
- Refit Existing Truck Tail lamps to rear
- Supply and install Mudguard assembly over drive axles
- No allowance for the modification of chassis length or the shifting of chassis cross members etc to allow body fitment if required

Unit Price	<b>\$80,000</b>
GST	\$88,000
<b>Total</b>	<b><u>\$88,000</u></b>

Yours Sincerely

Mitch Lang  
 Trailer sales Representative  
 0488083228

Should you wish to alter this quote, a new quote document is to be completed and signed.

Accepted by \_\_\_\_\_

On accepting this quote a deposit 20% is required prior to commencement of the job.  
 A signed form is to be retained by the client and Bruce Rock Engineering

See TERMS AND CONDITIONS OF SALE (attached).

(Company Directors - By signing this document as a Director you are personally guaranteeing payment if the company is unable to make payment.)

**INDUSTRY LEADING TECHNOLOGY**

- Tippers
- Dollies
- Drop Decks
- Flat Tops
- Skel Trailers
- Refrigerated + Dry Vans
- Maintenance + Repairs
- Spare Parts



### Terms and Conditions of Sale

#### QUOTATIONS

Prices are valid for 30 days from the date on which the offer document was signed.  
Bruce Rock Engineering may withdraw the offer at any time prior to the signing of the document by the client.  
Variations to the agreement shall be in writing and signed by both parties prior to being incorporated in the original contract.

#### TERMS OF PAYMENT

A deposit of 20% of the agreed price shall be paid on confirmation of the order and prior to commencement of work.  
The outstanding balance shall be due and payable on the handover of the equipment.  
Goods must be collected within seven days of notification of completion to avoid penalties.

#### VARIATIONS

Variations as requested by the client shall be agreed in writing prior to inclusion in the production of the equipment and shall be invoiced in detail as additions to the original quote. Where, for any reason credit is extended, any amount outstanding for more than 30 days from date of invoice shall have a 1.5% per month service fee on the outstanding balance added as a variation to the contract.

#### RETENTION OF TITLE

Title in the equipment is retained by Bruce Rock Engineering until the product is paid in full.

#### TERMINATION OF THE CONTRACT

If the client cancels the order prior to commencement of work the deposit shall be returned. Where the client cancels the contract after work has commenced the deposit shall be forfeit and applied against any outstanding costs of labour and materials including but not limited to the legal cost of recovery of debt incurred for breach of contract by the purchaser.

#### DELIVERY

Estimated delivery dates are estimates only and time shall not be of the essence of the agreement unless specifically included or as a mutually agreed variation to the contract.

#### INSPECTION AND ACCEPTANCE

The equipment must be inspected by the purchaser on delivery. Any claims for faulty workmanship or parts shall be made in writing within 2 weeks of the handover.

#### DUTIES & FEES

The buyer must pay all stamp, transaction, license, registration and similar duties taxes or fees.

#### DELIVERY INDEMNITY

The purchaser shall accept the risk of transport and use of the equipment on delivery and indemnify Bruce Rock Engineering against any claims for loss or damage how so ever arising after the delivery.

#### GUARANTEE

Bruce Rock Engineering guarantees to provide the product as specified on the quotation. Any faulty workmanship shall be rectified and defective parts shall be replaced free of charge within 12 months of the date of delivery of the equipment under the following conditions:  
The warranty applies to items manufactured by Bruce Rock Engineering only.  
Proprietary items supplied by Bruce Rock Engineering will be covered by that manufacturers own warranty terms and conditions.  
Faulty or defective equipment to be returned to Bruce Rock Engineering's workshop at the purchaser's cost; Essential repairs or alterations to enable the equipment to be returned to the workshop must be authorised by Bruce Rock Engineering; and failure to obtain authorisation from Bruce Rock Engineering shall void the warranty.

#### INDUSTRY LEADING TECHNOLOGY

- Tipper
- Dollies
- Drop Decks
- Flat Tops
- Skel Trailers
- Refrigerated + Dry Vans
- Maintenance + Repairs
- Spare Parts





# SHOGUN

**FUSO**

## Shogun FV70 6X4 - MY21

10.7L / AMT / MECH SUSP. / MWB

**OUR SAFEST AND CLEANEST SHOGUN YET. THE MY21 SHOGUN IS EQUIPPED WITH ABA5, PD, LDWS, ESP, AAA, IHC, DRL AND A EURO VI STEP D ENGINE. ALL BACKED BY OUR CLASS LEADING SERVICE INTERVALS AND 5 YEAR WARRANTY.**

**GVM**  

---

 25,400<sub>KG</sub>  

---

**GCM**  

---

 53,000<sub>KG</sub>  

---

**Power/Torque**  

---

 290<sub>KW</sub> / 2000<sub>NM</sub>  
 335<sub>KW</sub> / 2200<sub>NM</sub>  

---

- Heavy rigid licence required
- Actual vehicle may differ from above image

DAIMLER TRUCK **FUSO.COM.AU** **FUSO**  
JOB DONE

# SHOGUN SPECIFICATIONS

## MODEL

- A 6x4 FV70 395Hp Steel Susp. MWB 12 Sp. AMT FV70HK2VF5AA-MY21
- B 6x4 FV70 455Hp Steel Susp. MWB 12 Sp. AMT FV70HK4VF5AA-MY21

## WHEEL BASE

- 4300mm
- 4300mm

## GVM

- 25,400kg
- 25,400kg

## GCM

- 53,000kg
- 53,000kg

### Engine

Engine Version	A FUSO OM470-T2 Diesel	B FUSO OM470-T4 Diesel
Configuration	6 Cyl. In-line OHV	
Type	Asymmetric Turbocharger, Air to Air Intercooler	
Displacement	10.7 litre (10677 cc)	
Bore	125 mm	
Stroke	145 mm	
Power (DIN)	A 290 kW (395 hp) @ 1600 rpm	B 335 kW (455 hp) @ 1600 rpm
Torque (DIN)	A 2000 Nm (1475 lb.ft) @ 1100 rpm	B 2200 Nm (1622 lb.ft) @ 1100 rpm
Maximum Engine Speed	2100 rpm	
Compression Ratio	18.5:1	
Air Cleaner	Paper Element Type with Restrictor Indicator. Vertical Intake Mounted on Clean Air Side (RH)	
Emission Control	Diesel Particulate Filter (DPF) plus SCR After-Treatment System	
Emission Level	ADR 80/03 - Euro VI	

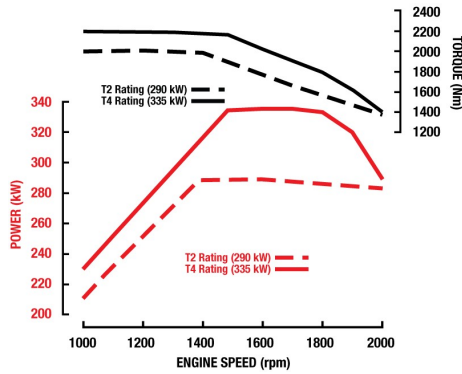

### Fuel

Injection System	Common Rail Direct Injection with Pressure Booster
Tank Type	Rectangular Alloy Tank with Locking Cap
Fuel Capacity *	400 Litres
Filtration	Filter with Water Separator and Dash Indicator
AdBlue Exhaust Fluid Capacity	60 Litres, Tank fitted with locking AdBlue cap
Speed Limiter	Speed Limited 100km/h
Notes	*Max Fill to approx 95% of Air Capacity

### Cooling

Fan Drive	Electronically controlled (Viscous)
Radiator	Corrugated Fin with Expansion Tank

### Electrical

Voltage	24V Negative Ground
Battery Capacity	2x12V, 150Ah/20hr
Battery Specification	2x145G51 (N150)
Headlamp Type	Automatic Type
	Low Beam: LED
	High Beam: Halogen
Fog Light	Halogen
Daytime Running Lamps	LED

### Clutch

Clutch Model	FUSO K4/430
Type	Single Dry Plate
Operation/Specification	Automated Manual (no clutch pedal)

### Transmission

Version	FUSO Automated Manual G230-12
Type/Speeds	12 Speed Automated Manual with Auto, Economy and Manual Modes
Features	Crawler Mode Skip Shift Function for Light Loads ECO Mode to Minimise Fuel Usage
Ratios	1st: 11.672 2nd: 9.101 3rd: 7.055 4th: 5.501 5th: 4.400 6th: 3.430 7th: 2.652 8th: 2.068 9th: 1.603 10th: 1.250 11th: 1.000 12th: 0.779 RHigh: 9.101 RLow: 11.672 Torque limited from 1st to 3rd and Reverse
PTO Opening	Rear of Transmission

### Propeller Shaft

Type	Single Main Shaft GW5E2200 Inter-axle Shaft P12
------	-------------------------------------------------

### Front Axle

Axle Version	FUSO F900T
Type	Reverse Elliot 'I' Beam
Capacity *	7100kg
Notes	*See MAX LOADING for vehicle capacity.

### Front Suspension

Type	Long Taper Leaf with Stabiliser Bar and Double Acting Shock Absorbers
Size	1500x90mm Leaves

### Rear Axle

Type	Full Floating Hypoid Type Tandem Drive with Inter-Axle Diff Lock Optional Limited Slip Differential LSD to both Axles
Axle Version	FUSO R10TT/R10T
Capacity*	21600kg
Ratio	4.625:1
Notes	*See MAX LOADING for vehicle capacities

### Rear Suspension

Type	Mechanical Suspension
Details	Long Leaf Taper, 6 Rod Trunion
Size Main Leaves	1320x90mm

### Max Loading

Front	6500kg
Rear	21600kg
Total	25400kg

# SHOGUN SPECIFICATIONS

## MODEL

- A 6x4 FV70 395Hp Steel Susp. MWB 12 Sp. AMT FV70HK2VF5AA-MY21
- B 6x4 FV70 455Hp Steel Susp. MWB 12 Sp. AMT FV70HK4VF5AA-MY21

## WHEEL BASE

- 4300mm
- 4300mm

## GVM

- 25,400kg
- 25,400kg

## GCM

- 53,000kg
- 53,000kg

### Options

Options	A	B
Q48:	- Limited Slip	- Limited Slip
	Differential - LSD	Differential - LSD
Q49:	- Limited Slip	- Limited Slip
	Differential - LSD	Differential - LSD
	- Engine Flywheel PTO 650N	- Engine Flywheel PTO 650N

### Steering

Type	Integral Ball and Nut
Steering Column	Tilt/Telescopic Adjustable

### Brakes

Type	Full Air, Dual Circuit with FUSO Taper Rollers
Size Front	410x160mm
Size Rear	410x200mm
Features	Brake Priority System
Park Brake	Rear Wheel Spring Actuated
Engine	Jacobs Brake 3 Levels of Retardation
Trailer	Hand Control Valve, Air Lines Coupling and Electrical Cable

### Wheels & Tyres

Wheel Type	10, Single Piece Alloy Disc
Wheel Size	22.5x8.25DC
Wheel Stud Pattern	10x335mm PCD
Tyre Brand	Bridgestone
Tyre Size Front	295/80R22.5 152/148
Tyre Size Rear	11R22.5 148/145

### Chassis

Type	Reinforced Parallel Channel
Size	300x90x7.0 mm
Width	840 mm
Tensile Strength	540 MPa

### Instruments

Gauges	Speedometer Tachometer Fuel Level Air Pressure AdBlue Level
Colour Information Display	Odometer Tripmeter (x2) Hour Meter (x2) Outside Temperature AdBlue Level DPF Information Driving Range (Fuel and AdBlue) Current Vehicle Speed Cruise Control Lane Departure Warning Active Attention Assist Warning Alarm Clock Level Control Service Indicator & Reminder System Air Pressure Coolant Temperature Engine Oil Level & Running Time
Warning Lamps	ABS ASR ESP ESP Off Turn Signal Headlamps High Beam Hill Holder Auxiliary Brake Parking Brake Engine Over-speed Air Pressure Low Height Control Cab Tilt Lock DPF Regeneration DPF Status AdBlue Empty AdBlue Contamination Active Brake Assist
Warning Lamp/Buzzer	Air Pressure Cab Tilt Engine Over-speed AdBlue Empty AdBlue Contamination

### Multi-Media Package

Satellite Navigation	Maps with heavy vehicle weight, length, height & hazardous material selectable restrictions with 3 years of Map updates
Colour Display	7 inch LCD with touch screen control
Phone Connectivity	Bluetooth® hands free
Audio Visual Entertainment	Bluetooth® music streaming compatible Digital radio DAB+ (also AM/FM for areas not covered by DAB+) USB & 3.5mm/AUX port
Reversing Camera Compatible	Display can accept up to 5 cameras#
Optional Accessories (available at additional cost)	Rear Mounted Parking Sensor Kit High or Low Tyre Pressure Monitoring System
Notes	# Cameras available through spare parts

# SHOGUN SPECIFICATIONS

## MODEL

A	6x4 FV70 395Hp Steel Susp. MWB 12 Sp. AMT FV70HK2VF5AA-MY21
B	6x4 FV70 455Hp Steel Susp. MWB 12 Sp. AMT FV70HK4VF5AA-MY21

## WHEEL BASE

4300mm
4300mm

## GVM

25,400kg
25,400kg

## GCM

53,000kg
53,000kg

### Standard Features

Cruise Control	Adaptive with Stop and Go
Hill Start System	Yes
Cab Cooling & Heating	Climate Control
Accessory Power	24V Accessory Power Outlet (x2) plus Cigar Lighter
Driving	Suspended Driver's Seat Central Locking Electric Windows LH Transom Window Opening Rear Quarter Glass Cup Holder Fluorescent Cabin Lamp Trailer Package including Trailer 'Stretch Brake'
Storage	Centre Storage Compartments (x3 Total, Lockable x1) Driver's Overhead Storage Door Storage Pockets Coat Hooks
Cab: External	Fog Lights Door Side Impact Beams Roof Mounting Points max. static load 70kg Front End-Outline Marker Lamps External PTO controls
Chassis	Integrated Front Underrun System (FUPS) Reverse Warning Buzzer Clear Top of Chassis Rail for ease of Body Fitment

### Cab Features

Type	All Steel Forward Control Elec / Hyd Tilt Cab
Cab Structure	ECE-R29 Standard
Mounting	Air Suspended Front and Rear
Colour	Natural White
Windscreen Wipers	Automatic 2 Speed + Intermittent Cycle with Integrated Washer Nozzles
Rear Vision Mirrors	2 x External Flat Main Mirrors Plus Convex Spotters Motorised Main Mirrors, All Mirrors Heated
Seating Capacity	2
Seat Belts	2 x Lap Sash with ELR. Driver pre-tensioner
Seat (driver)	Air Suspension with Height, Tilt and Dampening Adjustment Integral Headrest and Fabric Trim
Seats (passenger)	Single Fixed
Sleeping	ADR42/04 Approved Sleeping Berth

### Active Safety

Safety Systems	ABA5 - Active Brake Assist 5 PD - Pedestrian Detection AAA - Active Attention Assist PCA - Proximity Control Assist Cruise Control LDWS - Lane Departure Warning System ESP - Electronic Stability Program ABS - Anti-lock Braking System ASR - Anti Slip Regulator LED Headlamps DRL - Daytime Running Lamps IHC - Intelligent Headlight Control
Reverse Warning	Wide Dynamic Range Camera and Buzzer
Notes	Active Safety Systems primary function is to provide driver assistance to increase road safety in events of driver inattentiveness. These systems do not allow for lack of attention whilst driving and should not replace safe and alert driving.

### Passive Safety

Airbags	SRS Airbag - Driver
Body Strength	ECE-R29 Cab Strength Compliant
Seat Belts - Driver & Driver Assistant	3 Point ELR Lap Sash, Driver Pre-Tensioner.

### Service Intervals

Interval*	50,000km or 12 Months (whichever occurs first)
Notes	* based on normal operating conditions and may be reduced when operating under severe conditions.

### Warranty

Basic/Powertrain	5 Years or 500,000kms (whichever occurs first)
Cab Perforation/Anti Corrosion	5 Years

### Performance

Turning Circle (kerb to kerb - metres)	15.2
Electronically Speed Limited to:	100km/hr Conforms to ADR65/..
Engine Speed (rpm) at 100km/hr (top gear)	1879
Gradeability at Rated GVM (theoretical)*	A 61% B 66%
Gradeability at Rated GCM (theoretical)*	28.5%
Notes	*This is theoretical performance only. Actual performance may vary under different conditions

### Mass estimated\*

Front*	A 4323kg B 4363kg
Rear*	A 3347kg B 3342kg
Total*	A 7670kg B 7705kg
Notes	* Mass (est.) includes oil and water but excludes spare wheel, tools & fuel. Weights provided are subject to 3.5% variation (+/-)

### Dimensions mm

WFF (Width Front Fender) (mm)	2490
WRA (Width Rear Axle) (mm)	2475
WFT (Width Front Track) (mm)	2075
WRT (Width Rear Track) (mm)	1865
Width Frame (mm)	840
A - Length Overall (mm)	7640
B - Extreme Axle Spacing (mm)	4960
C - Front Overhang (mm)	1370
D - Wheelbase (mm)	4300
F - Rear Axle Spacing (mm)	1320
G - Front Axle to Rear of Cab (mm)	700
H - Rear of Cab to Rearmost Item Behind Cab (mm)	145
I - Rearmost Item Behind Cab to Rear Axle (mm)	3455
J - Frame, Rear Axle to End (mm)	1970
N - Height Overall (mm)	3300
O - Air Intake to Cab Roof (mm)	205
P - Height Cab to Ground (mm)	3095
Q - Height Cab to Frame (mm)	2090
R - Height Rear Frame to Ground (mm)	1058

DAIMLER TRUCK

FUSO.COM.AU

**FUSO**

**JOB DONE**



# SHOGUN SPECIFICATIONS

**MODEL**

- A 6x4 FV70 395Hp Steel Susp. MWB 12 Sp. AMT FV70HK2VF4A-MY21
- B 6x4 FV70 455Hp Steel Susp. MWB 12 Sp. AMT FV70HK4VF4A-MY21

**WHEEL BASE**

- 4300mm
- 4300mm

**GVM**

- 25,400kg
- 25,400kg

**GCM**

- 53,000kg
- 53,000kg

**Body Builder's Notes**

Notes

Chassis reinforcement must be utilised for Tipper/Demountable type body configurations. To conform with ADR 13/00 (lighting requirements) the following must be adhered to at body installation.

- If other than a flat type or tipper body is fitted, rear end out-line marker lamps must be installed.
- If overall length exceeds 6.0 metres, side reflectors must be installed.
- If overall length exceeds 7.5 metres, side marker lamps must be installed.

To conform with ADR 42/04 (General Safety), rear wheel guards must be fitted to the vehicle.



**Call 1800 033 557**

or visit [fuso.com.au](http://fuso.com.au)

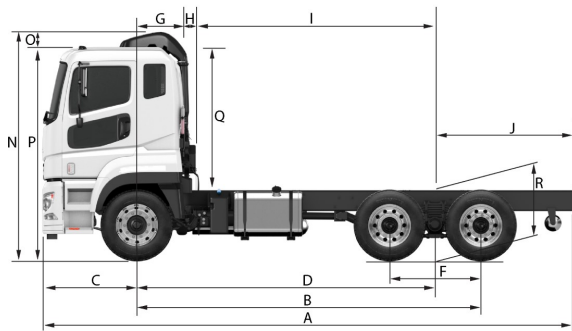
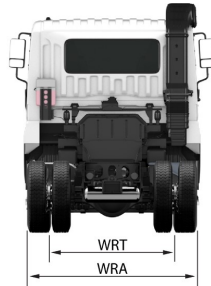

Unless specified in writing herein the accessories, applications, bodies or equipment depicted in this are for illustration purposes only and may not be available from Daimler Truck Australia Pacific Pty Ltd. ABN 86 618 413 282 DTAuP. No representation or warranty whatsoever is given in relation to any accessories, applications, bodies or equipment or suitability of same that are shown herein that may be manufactured, supplied or fitted by a party other than DTAuP. DTAuP reserves the right without notice or obligation to discontinue or make changes to the colour, designs, materials and specifications of the products and options referred to herein at any time. For the most current information and in order to ascertain which accessories, applications, bodies and equipment are available from DTAuP please contact your authorised FUSO dealer. Fuso is a registered trademark of Daimler Truck Australia Pacific Pty Ltd. Copyright DTAuP. Reproduction in whole or part prohibited without written approval. Valid from 12-Aug-21.

**MAJOR MOTORS PTY LTD**  
 ACN 008 996 174 ATF THE MAJOR MOTORS UNIT TRUST ABN 65 730 475 316  
 Trading As MAJOR MOTORS DL1141 MRB 1908 ARC AU03039



Branch: HEAD OFFICE  
 789 Abernethy Rd  
 Forrestfield WA 6058  
 PH (08) 9365 6333  
 Fax: (08) 9365 6366

Branch: BIBRA LAKE  
 2 Selkis Road  
 Bibra Lake WA 6163  
 Phone: (08) 9331 9331  
 FAX: (08) 9331 9339

Postal: PO Box 163 Belmont WA 6984 Web: www.majormotors.com.au

Branch: PORT HEDLAND  
 1 Quirinup Way  
 Port Hedland WA 6721  
 Phone: (08) 9172 6900  
 FAX: (08) 9172 6966

Branch: MALAGA  
 65 Crocker Drive  
 Malaga WA 6090  
 Phone: (08) 9241 7999  
 FAX: (08) 9241 7810



**Customer :**  
 Shire of Quairading  
 PO Box 38,  
 QUAIRADING WA 6383

DOB.: Driver Licence:  
 Email: shire@quairading.wa.gov.au

A.B.N. 24 167 484 077  
 A.C.N.  
 Mobile: 0427 451 001  
 Fax: 08 9645 1126  
 Business: 08 9645 2400  
 Private:

**Quote Details :**

Page 1 / 2  
 Quote / Deal ID: 56831  
 Customer Order:  
 Quotation Date: 12/10/2023  
 Quote Expiry Date: 11/11/2023  
 Salesperson: Lauren Nicholls

**Vehicle :**

Rego No: TBA  
 VIN No: TBA  
 Vehicle ID: TBA  
 Odometer:

Rego Expiry:  
 EngineNo:  
 Compliance Date: /  
 Build Date:

**Driver :**

D.O.B.:  
 Driver Lic:  
 Full Name:  
 Phone:

**NEW VEHICLE:** Make ISUZU TRUCK  
 Model FXZJJ-L23 FXZ 240-350 AUTO MLWB \$180,800.00

**OPTIONS:**

**GENUINE ACCESSORIES:**

**NON GENUINE ACC.:**

PTO switch for tipper operation \$650.00  
 Ski bar to cab roof with two LED amber beacons and illuminated switch in cab \$2,870.00  
 Window tint \$610.00  
 Weather shield to drivers door \$230.00  
 GME TX3550 80 channel two way radio \$1,130.00  
 Rubber floor mats \$220.00  
 Reverse camera Standard Item  
 6 year / 600,000km / 10,000 hour factory warranty Standard Item  
 Delivery to Shire of Quairading with operator handover Inclusive Item

**AFTERMARKET ACC.:**

11 cubic metre two way tipping body by TL Engineering with: \$89,950.00  
 - 5mm Hardox construction with heavy duty ribs for additional strength  
 - Two way air operated tailgate  
 - Access rungs with drop down ladder  
 - Shovel and broom racks  
 - Mesh tail light protection  
 - 30T under body hoist  
 - Hotshift PTO to suit Allison transmission  
 - Sandblasted and painted white to match cab  
 PH300 air cushion pintle hook tow hitch with hydraulics to rear, ABS and 12v plugs \$5,550.00  
 Electric retractable tarp to headboard \$8,250.00  
 Hand and foot air trailer brakes \$2,400.00  
 Winch type spare tyre carrier to headboard \$2,150.00  
 Fit tyre to spare rim \$1,100.00  
 Canvas seat covers \$440.00

**DEALER DELIVERY:** CARRIED OUT PRE-DELIVERY INSPECTION \$0.00

Vehicle Sub-Total excluding G.S.T.	\$296,350.00
G.S.T. Payable	\$29,635.00
<b>Vehicle Sub Total Inclusive of G.S.T.</b>	<b>\$325,985.00</b>

**GST EXCLUSIVE ITEMS:** Registration - approx - charged at cost (Business) \$700.00

**OTHER INSURANCE:**

**VEHICLE TOTAL INCLUSIVE OF GST \$326,685.00**

**LESS TRADE(S):** Rego: Q272 Nissan UD Quon 26 380 Tipper -105,000.00  
 km 192150

**LESS DEPOSIT:**

**BALANCE PAYABLE ON DELIVERY \$221,685.00**

**MAJOR MOTORS PTY LTD**  
 ACN 008 996 174 ATF THE MAJOR MOTORS UNIT TRUST ABN 65 730 475 316  
 Trading As MAJOR MOTORS DL1141 MRB 1908 ARC AU03039



Branch: HEAD OFFICE  
 789 Abernethy Rd  
 Forrestfield WA 6058  
 PH (08) 9365 6333  
 Fax: (08) 9365 6366

Branch: BIBRA LAKE  
 2 Seikis Road  
 Bibra Lake WA 6183  
 Phone: (08) 9331 9331  
 FAX: (08) 9331 9339

Postal: PO Box 163 Belmont WA 6984 Web: www.majormotors.com.au

Branch: PORT HEDLAND  
 1 Quinlup Way  
 Port Hedland WA 6721  
 Phone: (08) 9172 6900  
 FAX: (08) 9172 6966

Branch: MALAGA  
 65 Crocker Drive  
 Malaga WA 6090  
 Phone: (08) 9241 7999  
 FAX: (08) 9241 7910



<b>Customer :</b>		<b>Quote Details :</b>	
Shire of Quairading PO Box 38, QUAIRADING WA 6383	A.B.N. 24 187 484 077 A.C.N. Mobile: 0427 451 001 Fax: 08 9645 1126 Business: 08 9645 2400 Private:	Page 2 / 2 Quote / Deal ID: 56831 Customer Order: Quotation Date: 12/10/2023 Quote Expiry Date: 11/11/2023 Salesperson: Lauren Nicholls	
DOB.: Email: shire@quairading.wa.gov.au	Driver Licence:		

<b>Vehicle :</b>		<b>Driver :</b>	
Rego No: TBA VIN No: TBA Vehicle ID: TBA Odometer:	Rego Expiry: EngineNo: Compliance Date: / Build Date:	D.O.B.: Driver Lic: Full Name: Phone:	

**CONDITIONS OF QUOTATION:**

The Dealer reserves the right to amend pricing should the Manufacturer's or third Parties prices or Government charges change prior to delivery.  
 Trade-in prices are based on vehicle condition at time of Quotation and the quote is valid until 11/11/2023 only. Trade-in values are inclusive of GST.

  
 Salesperson: Lauren Nicholls

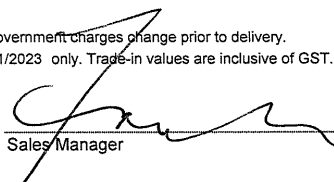
  
 Sales Manager

Document Printed On 12/10/2023 12:39:45 PM

**MAJOR MOTORS PTY LTD**  
 ACN 008 996 174 ATF THE MAJOR MOTORS UNIT TRUST ABN 65 730 475 316  
 Trading As MAJOR MOTORS DL1141 MRB 1908 ARC AU03039



Branch: HEAD OFFICE  
 789 Abernethy Rd  
 Forrestfield WA 6058  
 PH (08) 9365 6333  
 Fax: (08) 9365 6366

Branch: BIBRA LAKE  
 2 Selkis Road  
 Bibra Lake WA 6183  
 Phone: (08) 9331 9331  
 FAX: (08) 9331 9339

Branch: PORT HEDLAND  
 1 Quinrup Way  
 Port Hedland WA 6721  
 Phone: (08) 9172 6900  
 FAX: (08) 9172 6966

Branch: MALAGA  
 65 Crocker Drive  
 Malaga WA 6090  
 Phone: (08) 9241 7998  
 FAX: (08) 9241 7910

Postal: PO Box 163 Belmont WA 6984 Web: www.majormotors.com.au



**Customer :**  
 Shire of Quairading  
 PO Box 38,  
 QUAIRADING WA 6383

**DOB.:** Driver Licence:  
**Email:** shire@quairading.wa.gov.au

**A.B.N.** 24 187 484 077  
**A.C.N.**  
**Mobile:** 0427 451 001  
**Fax:** 08 9645 1126  
**Business:** 08 9645 2400  
**Private:**

**Quote Details :**

**Page** 1 / 2  
**Quote / Deal ID:** 56833  
**Customer Order:**  
**Quotation Date:** 12/10/2023  
**Quote Expiry Date:** 11/11/2023  
**Salesperson:** Lauren Nicholls

**Vehicle :**

**Rego No:** TBA  
**VIN No:** TBA  
**Vehicle ID:** TBA  
**Odometer:**

**Rego Expiry:**  
**EngineNo:**  
**Compliance Date:** /  
**Build Date:**

**Driver :**

**D.O.B.:**  
**Driver Lic:**  
**Full Name:**  
**Phone:**

**NEW VEHICLE:** Make ISUZU TRUCK  
 Model FXZJJ-L23 FXZ 240-350 AUTO MLWB \$180,800.00

**OPTIONS:**

**GENUINE ACCESSORIES:**

**NON GENUINE ACC.:**

- PTO switch for tipper operation \$650.00
- Ski bar to cab roof with two LED amber beacons and illuminated switch in cab \$2,870.00
- Window tint \$610.00
- Weather shield to drivers door \$230.00
- GME TX3550 80 channel two way radio \$1,130.00
- Rubber floor mats \$220.00
- Reverse camera Standard Item
- 6 year / 600,000km / 10,000 hour factory warranty Standard Item
- Delivery to Shire of Quairading with operator handover Inclusive Item

**AFTERMARKET ACC.:**

- 11 cubic metre two way tipping body by TL Engineering with: \$89,950.00
  - 5mm Hardox construction with heavy duty ribs for additional strength
  - Two way air operated tailgate
  - Access rungs with drop down ladder
  - Shovel and broom racks
  - Mesh tail light protection
  - 30T under body hoist
  - Hotshift PTO to suit Allison transmission
  - Sandblasted and painted white to match cab
- PH300 air cushion pintle hook tow hitch with hydraulics to rear, ABS and 12v plugs \$5,550.00
- Electric retractable tarp to headboard \$8,250.00
- Hand and foot air trailer brakes \$2,400.00
- Winch type spare tyre carrier to headboard \$2,150.00
- Fit tyre to spare rim \$1,100.00
- Canvas seat covers \$440.00

**DEALER DELIVERY:** CARRIED OUT PRE-DELIVERY INSPECTION \$0.00

Vehicle Sub-Total excluding G.S.T.	\$296,350.00
G.S.T. Payable	\$29,635.00
<b>Vehicle Sub Total Inclusive of G.S.T.</b>	<b>\$325,985.00</b>

**GST EXCLUSIVE ITEMS:** Registration - approx - charged at cost (Business) \$700.00

**OTHER INSURANCE:**

**VEHICLE TOTAL INCLUSIVE OF GST \$326,685.00**

**LESS TRADE(S):** Rego: Q5122 Nissan UD GW 26 400 Tipper  
 km 265571 -\$100,000.00

**LESS DEPOSIT:**

**BALANCE PAYABLE ON DELIVERY \$226,685.00**

**MAJOR MOTORS PTY LTD**

ACN 008 996 174 ATF THE MAJOR MOTORS UNIT TRUST ABN 65 730 475 316  
Trading As MAJOR MOTORS DL1141 MRB 1908 ARC AU03038



Branch: HEAD OFFICE  
789 Abernethy Rd  
Forrestfield WA 6058  
PH (08) 9365 6333  
Fax: (08) 9365 6366

Branch: BIBRA LAKE  
2 Selkis Road  
Bibra Lake WA 6163  
Phone: (08) 9331 9331  
FAX: (08) 9331 9339

Branch: PORT HEDLAND  
1 Quinrip Way  
Port Hedland WA 6721  
Phone: (08) 9172 6900  
FAX: (08) 9172 6966

Branch: MALAGA  
65 Crocker Drive  
Malaga WA 6090  
Phone: (08) 9241 7999  
FAX: (08) 9241 7910

Postal: PO Box 163 Belmont WA 6984 Web: www.majormotors.com.au



<b>Customer :</b> Shire of Quairading PO Box 38, QUAIRADING WA 6383  DOB.: Driver Licence: Email: shire@quairading.wa.gov.au		<b>Quote Details :</b> Page 2 / 2 Quote / Deal ID: 56833 Customer Order: Quotation Date: 12/10/2023 Quote Expiry Date: 11/11/2023 Salesperson: Lauren Nicholls	
<b>Vehicle :</b> Rego No: TBA VIN No: TBA Vehicle ID: TBA Odometer:		A.B.N. 24 187 484 077 A.C.N. Mobile: 0427 451 001 Fax: 08 9645 1126 Business: 08 9645 2400 Private:  Rego Expiry: EngineNo: Compliance Date: / Build Date:	
		<b>Driver :</b> D.O.B.: Driver Lic: Full Name: Phone:	

**CONDITIONS OF QUOTATION:**

The Dealer reserves the right to amend pricing should the Manufacturer's or third Parties prices or Government charges change prior to delivery.  
Trade-in prices are based on vehicle condition at time of Quotation and the quote is valid until 11/11/2023 only. Trade-in values are inclusive of GST.

  
Salesperson: Lauren Nicholls

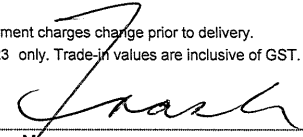
  
Sales Manager

Document Printed On 12/10/2023 12:41:56 PM

# FX SERIES

**ISUZU**  
RELIABILITY IS EVERYTHING

**FX2 240-350 6X4**  
**FX4 240-350 6X4**



FX4 MODEL PICTURED

**WEIGHT RATINGS\***

**GVM** 24,000 kg  
**GCM** 45,000 kg

**ENGINE**

**POWER** 257 kW @ 2,000 rpm  
**TORQUE** 1,422 Nm @ 1,400 rpm

**TRANSMISSION**

9 speed manual transmission (MT)  
6 speed automatic transmission (AT)

\* Refer to back page for detailed weight rating information

ISUZU CARE	
<b>WARRANTY</b>	6 Year Standard Warranty 600,000 km / 10,000 Engine Hours
<b>ROADSIDE ASSIST</b>	6 Year Roadside Support 24/7 Unlimited km
<b>HARSH APPLICATION WARRANTY (CONCRETE AGITATOR / GARBAGE COMPACTOR)</b>	3 Year Standard Warranty 300,000 km / no hours stipulation 3 Year Roadside Support 24/7 Unlimited km



Subject to the conditions outlined in the IAL New Vehicle Warranty. For further information please visit [isuzu.com.au](http://isuzu.com.au) or contact your local dealer.

INTELLIGENT SAFETY	
<b>STANDARD FEATURES</b>	Anti-Lock Braking System (ABS)
	Driver airbag
	Driver seatbelt pretensioner
	Low light capable reversing camera
	ECE-R29 compliant cab

SERVICE AGREEMENTS			
Optional Service Packages	ESSENTIALS	ESSENTIALS PLUS	TOTAL
<b>SCHEDULED SERVICINGS</b>	●	●	●
<b>CONSUMABLES</b>		●	●
<b>ENGINE, TRANSMISSION &amp; DRIVELINE</b>			●
<b>EXTRAS</b>	After-hours Servicing, Glass, Fuel Card, Pickup - Dropoff		

**FXZ 240-350 6X4**  
**FXV 240-350 6X4**

ENGINE	
<b>DESCRIPTION</b>	Isuzu 6UZ1-TCN
<b>TYPE</b>	6 cylinder 24 valve SOHC
<b>DISPLACEMENT</b>	9,839 cc
<b>COMPRESSION RATIO</b>	17.5:1
<b>BORE X STROKE</b>	120 mm x 145 mm
<b>POWER</b>	257 kW (350PS) @ 2,000 rpm (DIN NET)
<b>TORQUE</b>	1,422 Nm @ 1,400 rpm (DIN NET)
<b>INDUCTION</b>	Electronically controlled variable nozzle turbocharger with air-to-air intercooler
<b>FUEL INJECTION</b>	Direct injection high pressure common rail
<b>EMISSION CONTROL</b>	Cooled EGR with exhaust Diesel Oxidation Catalyst (DOC). ADR 80/03 (Euro V) compliant.

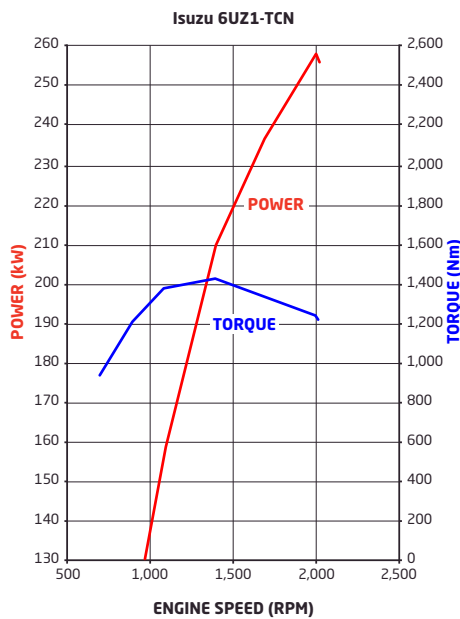

TRANSMISSION		
<b>MT</b>	<b>CLUTCH</b>	Type: Single plate with air assisted hydraulic control Clutch plate diameter: 432 mm Clutch lining area: 1,923 cm <sup>2</sup>
	<b>GEARBOX</b>	Description: ZF 9S 1310 TO Type: 9 speed with synchromesh on gears 1-8 Ratios: Crawler 1st 2nd 3rd 4th 5th 6th 7th 8th Rev 9.48 6.58 4.68 3.48 2.62 1.89 1.35 1.00 0.75 8.97
		Power Take Off facility: Provision at rear of transmission case Other features: Repeat 'H' shift pattern
		Description: Allison 4430 Type: 6 speed automatic Ratios: 1st 2nd 3rd 4th 5th 6th Rev 4.70 2.21 1.53 1.00 0.76 0.67 5.55
	Power Take Off facility: LHS and top openings on transmission bellhousing. Engine driven PTO drive gear. Other features: 5th generation electronic controls with adaptive shift. Long life TranSynd synthetic fluid.	

AXLES	
<b>FRONT</b>	<b>Description:</b> Meritor FG941
	<b>Type:</b> Reverse Elliot I-beam
	<b>Capacity:</b> 6,600 kg
<b>REAR</b>	<b>Description:</b> Meritor MT-14X
	<b>Type:</b> Tandem drive
	<b>Other features:</b> Inter-axle lock and cross locks fitted to both axles
	<b>Capacity:</b> 18,100 kg
<b>Ratio:</b> 4.875:1 (except FXZ/FXY AUTO MLWB models), 5.286:1 (FXZ/FXY AUTO MLWB models)	

SUSPENSION	
<b>FRONT</b>	<b>Type:</b> Single stage alloy steel taper-leaf springs
	<b>Other features:</b> Double acting hydraulic shock absorbers. Stabiliser bar.
<b>REAR</b>	<b>FXZ</b> <b>Type:</b> Taper leaf spring with Isuzu 6 rod and trunnion location system
	<b>FXV</b> <b>Description:</b> Hendrickson HAS461
	<b>Type:</b> Airbag <b>Capacity:</b> 20,865 kg at ground

BRAKES	
<b>DESCRIPTION</b>	Meritor 'Q-Plus'
<b>TYPE</b>	Full air 'S-Cam' front and rear drum brakes
<b>DIAMETER X WIDTH FRONT</b>	419 x 127 mm
<b>DIAMETER X WIDTH REAR</b>	419 x 178 mm
<b>PARK BRAKE</b>	Spring park brake acting on all rear wheels
<b>AUXILIARY BRAKE</b>	Air controlled exhaust brake

STEERING	
<b>TYPE</b>	Power assisted recirculating ball
<b>GEAR RATIO</b>	18.5:1
<b>TURNS LOCK TO LOCK</b>	3.7
<b>WHEEL LOCK ANGLE</b>	40° (inside wheel) / 32° (outside wheel)

WHEELS & TYRES		
<b>FRONT</b>	<b>WHEELS</b>	22.5 x 8.25 ten stud ISO standard steel wheels
	<b>TYRES</b>	295/80R22.5 152/148M Michelin X Multi Z 2 Tubeless
	<b>STEER AXLE TYRE RATING</b>	7,100 kg
<b>REAR</b>	<b>WHEELS</b>	22.5 x 8.25 ten stud ISO standard steel wheels
	<b>TYRES</b>	11R22.5 148/145L Michelin X Multi D Tubeless
	<b>TANDEM AXLE TYRE RATING</b>	23,200 kg
<b>SPARE</b>	Rim supplied. Winch type carrier (except FXZ MLWB).	

CHASSIS FRAME	
<b>TYPE</b>	Cold rivetted ladder frame.
<b>MATERIAL</b>	HT540A steel members
<b>DIMENSIONS</b>	Side rail (mm): 285 x 85 x 7.0 Rear frame width (mm): 850



FUEL TANK	
<b>TYPE</b>	Frame mounted aluminium fuel tank
<b>CAPACITY</b>	400 L
<b>FUEL CAP</b>	Lockable

ELECTRICAL SYSTEM	
<b>TYPE</b>	24 volt
<b>ALTERNATOR</b>	90 amp
<b>STARTER MOTOR</b>	5.0 kW
<b>BATTERY</b>	2 x 115E41L (651 CCA) batteries connected in series
<b>CAN BUS PROVISION</b>	Underdash CAN system access plug for connection to a Fleet Management System (FMS) (not supplied)

### CABIN SPECIFICATIONS & APPOINTMENTS

CABIN GENERAL FEATURES	
<b>ENGINE ACCESS</b>	Electro-hydraulic cab tilt
<b>CAB MOUNTING</b>	Rear coil spring suspension with hydraulic shock absorbers
<b>STEPS</b>	Heavy duty anti-slip steps
<b>DOORS</b>	90° opening internally reinforced front doors
<b>MIRRORS</b>	Heated and powered exterior main mirrors with flat glass and additional independently adjustable convex "spot" mirrors
<b>WIPERS</b>	Two speed windscreen wipers with intermittent wipe mode
<b>EXTERIOR LIGHTING</b>	LED main beam and halogen high beam headlamps. Chrome surround.
	Roof mounted clearance lamps
	Front foglamps
<b>AUDIBLE WARNING</b>	Reverse alarm
<b>GRILLE</b>	Chrome
<b>FRONT BUMPER</b>	Body coloured air dam type
<b>SECURITY</b>	Central locking with remote keyless entry and immobiliser

AUDIO VISUAL UNIT	
<b>SCREEN TYPE</b>	10.1" 1080p High Definition with capacitive touch
<b>NAVIGATION</b>	Truck tailored GPS based system + live feed traffic alerts and live feed route optimisation via smartphone link (live feed component is by subscription with first 3 years provided at no extra cost)
<b>OPERATING SYSTEM</b>	Android Automotive
<b>RADIO</b>	AM/FM/DAB+
<b>INTERNAL STORAGE CAPACITY</b>	32GB
	USB 3.0 socket
<b>SMARTPHONE INTEGRATION</b>	Wi-Fi connectivity
	Android Auto / Apple CarPlay compatible
	Phone storage pocket with wireless charging facility
<b>OTHER CAPABILITY</b>	Provision for external camera inputs, tyre pressure monitoring, low and high position reverse sensor inputs

CABIN INTERIOR	
<b>SEATING</b>	Isri 6860/875 NTS air suspension driver's seat
	Front passenger adjustable bucket seat and front centre seat with folding seat back
<b>SEATBELTS</b>	3-point lap sash seatbelts in all outboard seating positions. Driver seatbelt integrated with driver seat. Centre seat lap belts.
<b>STEERING COLUMN</b>	Tilt/telescopic adjustable
<b>ENTRY ASSIST GRIPS</b>	Door and roof pillar mounted
<b>DOOR WINDOWS</b>	Electric control
<b>STORAGE</b>	Overhead compartments
	Twin cup holders
	Centre console box and storage tray
	Passenger glovebox
<b>POWER OUTLET</b>	24V cigarette lighter
	2.4A high current fast charge USB socket
<b>AIRCONDITIONING</b>	Auto control
<b>INTERIOR LIGHTING</b>	Fluorescent lamp
<b>REAR COMPARTMENT</b>	ADR 42 compliant sleeper with mattress

DRIVER CONTROLS	
<b>ENGINE</b>	Idle speed control
	Cruise control
<b>TRANSMISSION (AT ONLY)</b>	Push button gear selection control
<b>GENERAL CONTROLS</b>	Headlamp on/off and levelling, windscreen wipers (2 speed and intermittent modes), washers, exhaust brake, turn signals
	Inter-axle lock and cross lock engage switches

INSTRUMENTATION	
<b>MULTI INFORMATION DISPLAY</b>	Vehicle systems status
	Low fuel level alert
	Fuel consumption information
	Service interval alerts
<b>GENERAL INSTRUMENTATION</b>	Hourmeter
	Adjustable vehicle speed warning
	Speedometer and tachometer
	Digital odometer with integrated dual tripmeters
	Transmission oil level, oil life, filter life, and condition monitor display (AT only)
	Engine coolant temperature, fuel level and air pressure gauges





**FXZ 240-350 6X4**  
**FXZ 240-350 6X4**



WEIGHTS (kg)							
MODELS	RATINGS*		LOADING LIMIT* (at ground)		CAB CHASSIS WEIGHT #		
	GVM	GCM	FRONT	REAR	FRONT	REAR	TOTAL
FXZ 240-350 AUTO MLWB	24,000	45,000	6,600	18,100	4,120	3,340	7,460
FXZ 240-350 LWB	24,000	45,000	6,600	18,100	3,945	3,540	7,485
FXZ 240-350 AUTO LWB	24,000	45,000	6,600	18,100	4,130	3,575	7,705
FXZ 240-350 AUTO MLWB	24,000	45,000	6,600	18,100	4,075	3,130	7,205
FXZ 240-350 LWB	24,000	45,000	6,600	18,100	3,925	3,320	7,245
FXZ 240-350 AUTO LWB	24,000	45,000	6,600	18,100	4,105	3,350	7,455

\* Vehicle ratings and front/rear weight limits are subject to government regulatory requirements and weight distribution analysis. Consult your Isuzu dealer to select the correct vehicle for your specific application.

# Cab chassis only as supplied and including 10 litres of fuel.

DIMENSIONS (mm)													(m)
MODELS	WB	OAL	FOH	ROH	EA	CE	RT	ORT	CH	FFA (unladen)	RFA (unladen)	RFH (unladen)	TURNING CIRCLE
													kerb to kerb
FXZ 240-350 AUTO MLWB	4,540	8,000	1,480	1,980	3,860	5,939	1,840	2,450	2,990	920	1,095	1,140	17.1
FXZ 240-350 LWB / AUTO LWB	6,010	10,990	1,480	3,500	5,330	8,950	1,840	2,445	2,990	920	1,100	1,140	22.7
FXZ 240-350 AUTO MLWB	4,540	8,000	1,480	1,980	3,860	5,939	1,840	2,450	2,990	920	1,050	1,070	17.1
FXZ 240-350 LWB / AUTO LWB	6,010	10,990	1,480	3,500	5,330	8,950	1,840	2,445	2,990	920	1,040	1,065	22.7

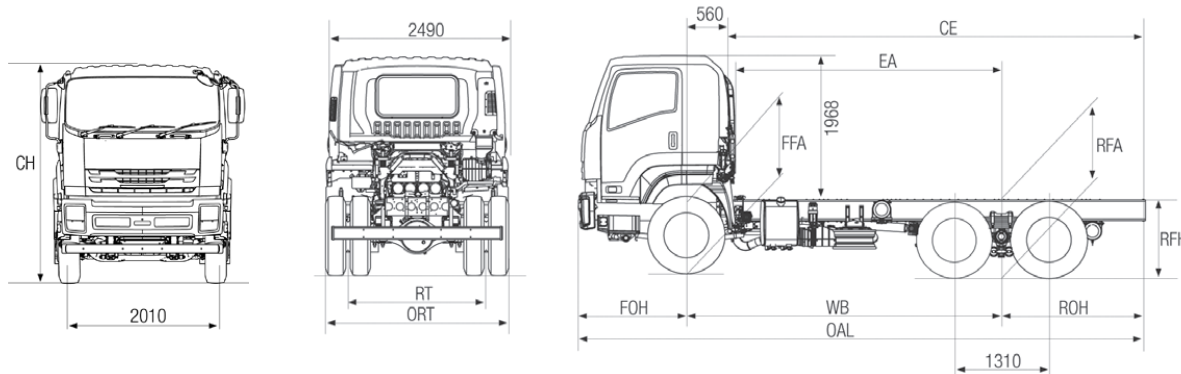

PERFORMANCE (calculated - typical paved road)					
		GEARED SPEED^ (top gear at peak power engine rpm)		LOW SPEED GRADEABILITY (lowest forward gear assuming no wheel slip)	ENGINE SPEED (top gear at 100 km/h)
		FXZ/FXZ 240-350 LWB	At 24,000 kg GVM	106 km/h @ 2,000 rpm	48%
FXZ/FXZ 240-350 AUTO MLWB	At 24,000 kg GVM	109 km/h @ 2,000 rpm	60%	1,830 rpm	
FXZ/FXZ 240-350 AUTO LWB	At 24,000 kg GVM	119 km/h @ 2,000 rpm	55%	1,690 rpm	

^ Maximum speed achievable depends on vehicle frontal area as well as other factors. Consult your Isuzu dealer for more detailed information. Vehicle is speed limited to 100km/h.

ORDER CODES	
MODELS	CODES
FXZ 240-350 AUTO MLWB	FH-FXZJJ-L22
FXZ 240-350 LWB	FH-FXZJJ-D22
FXZ 240-350 AUTO LWB	FH-FXZJJ-N22
FXZ 240-350 AUTO MLWB	FH-FXZJJ-L22
FXZ 240-350 LWB	FH-FXZJJ-D22
FXZ 240-350 AUTO LWB	FH-FXZJJ-N22

Subject to the conditions outlined in the IAL New Vehicle Warranty, Isuzu FX series models carry a standard factory warranty which covers the owner for the first 72 months or 600,000 kilometres or 10,000 Engine Hours (whichever comes first). All Isuzu warranties are subject to mandatory prescribed terms under Australian Consumer Law including consumer guarantees. Harsh Conditions variations to standard factory warranty may apply. For more details visit the Isuzu website at [www.isuzu.com.au](http://www.isuzu.com.au) which explains Isuzu warranties in more detail, or alternatively contact your local Isuzu Truck dealer. All warranties commence from date of initial delivery.

ISUZU AUSTRALIA LIMITED ABN 97 006 962 572 ("IAL"). The information in this spec sheet was correct at time of printing, but all measurements, specifications and equipment are subject to change without notice. Some equipment may have been changed and/or is available at extra cost. IAL may make changes at any time without notice, in prices, colours, materials, equipment and models. IAL makes all reasonable attempts to ensure the availability of all vehicles and equipment. The information in this spec sheet is general in nature. Your Isuzu dealer can confirm all measurements, specifications and vehicle / equipment availability upon request. To the extent permitted by the law, IAL is not liable to any person as result of reliance on the content of this spec sheet.

Response Details As at Thursday 12 October 2023 08:30 AM UTC

Response Request (VP380815) **VPR656986 Plant Acquisition - 2 x Tipper Trucks**

Supplier **Iveco Trucks Australia**  
 Validated Business Name **IVECO TRUCKS AUSTRALIA LTD**  
 Business Number **ABN 86 004 065 061**  
 Location **485 Great Eastern Hwy Redcliffe, Western Australia 6104 Australia**

These prices are **Fixed**

The following comments were added : TRUCK 1: Current Rego: & approx. ODO VIN: Model & Year of Manufacture: Q 272, 192,150 JNBCWB5EL00L00480 Nissan UD Quon 26 380, 2013 Assessed Trade Value EX GST - \$45,090.90 TRUCK 2: Current Rego: & approx. ODO VIN: Model & Year of Manufacture: Q 5122, 265 571 JNBGBW4DL00H00724 Nissan UD GW 26 400, 2012 Assessed Trade Value EX GST - \$35,090.90

Quoted items

Product	RC D%	#	Unit Price	Tax	Total Price
1 Iveco S-Way - 6x4 AS Cab 530HP 70 Tonne Rated - Stock #1035 & Stock #1036		2 x	\$249,191.80	\$49,838.36	\$548,221.96
2 Local Options - AV Truck Services Pre Delivery Workshop		2 x	\$5,950.00	\$1,190.00	\$13,090.00
3 Sub Contracted Options		2 x	\$80,500.00	\$16,100.00	\$177,100.00
4 Stamp Duty and On Road Costs		2 x	\$12,732.18	\$0.00	\$25,464.36
				\$67,128.36	\$763,876.32

Quoted items - Detailed View

Product	RC D%	#	Unit Price	Tax	Total Price
1 Iveco S-Way - 6x4 AS Cab 530HP 70 Tonne Rated - Stock #1035 & Stock #1036		2 x	\$249,191.80	\$49,838.36	\$548,221.96
Product	<b>Iveco S-Way - 6x4 AS Cab 530HP 70 Tonne Rated - Stock #1035 &amp; Stock #1036</b>				
Description	Not provided.				
Unit Price			\$249,191.80		
Quantity quoted		x 2			
Post Discount Total			\$498,383.60		
Tax Rate Applied (10.0%)			\$49,838.36		
TOTAL			<b>Tax Applied</b>	<b>\$548,221.96</b>	

Product	RC D%	#	Unit Price	Tax	Total Price
2 Local Options - AV Truck Services Pre Delivery Workshop		2 x	\$5,950.00	\$1,190.00	\$13,090.00
Product	<b>Local Options - AV Truck Services Pre Delivery Workshop</b>				
Description	- Amber Beacons, and bar with OEM Rocker Switch and Programming - Window Tint and OEM Weather Shield - OEM switches for Electric Tarpaulin in the Cab - GME 80 Channel UHF Supplied and Installed with Antenna mounted to light bar to not comprise the roof - Custom Cars Heavy Duty Custom Seat Covers and OEM heavy duty rubber floor mats - Delivery and handover to the shire of Quairading				
Unit Price			\$5,950.00		
Quantity quoted		x 2			
Post Discount Total			\$11,900.00		
Tax Rate Applied (10.0%)			\$1,190.00		
TOTAL			<b>Tax Applied</b>	<b>\$13,090.00</b>	

Product	RC D%	#	Unit Price	Tax	Total Price
3 Sub Contracted Options		2 x	\$80,500.00	\$16,100.00	\$177,100.00
Product	<b>Sub Contracted Options</b>				
Description	Park Body Builders - 11m3 2-Way Tipping Body				
Unit Price			\$80,500.00		
Quantity quoted		x 2			
Post Discount Total			\$161,000.00		
Tax Rate Applied (10.0%)			\$16,100.00		
TOTAL			<b>Tax Applied</b>	<b>\$177,100.00</b>	

Product	RC D%	#	Unit Price	Tax	Total Price
4 Stamp Duty and On Road Costs		2 x	\$12,732.18	\$0.00	\$25,464.36

Product	<b>Stamp Duty and On Road Costs</b>	
Description	• Approx. 12 Months License & Registration \$1,656.00 • Stamp Duty \$11,076.18	
Unit Price	\$12,732.18	
Quantity quoted	x 2	
Post Discount Total	<u>\$25,464.36</u>	
Tax Rate Applied (0.0%)	\$0.00	
TOTAL	No Tax Applied	<u><u>\$25,464.36</u></u>

	Tax	Total Price
	\$67,128.36	\$763,876.32



7 JACKSON STREET  
 BASSENDEAN, WA 6054  
 TELEPHONE: 08 9378 0600  
 FAX: 08 9378 2670  
[www.parkbodybuilders.com.au](http://www.parkbodybuilders.com.au)

**PARK BODY BUILDERS W.A**

**CLIENT NAME:** QUOTE No: DD/9/23  
**CONTACT:** CLIENT SPECIFICATION No:  
**PHONE No:** FAX or Email:

**STEEL 11m3 2-WAY TIPPING BODY**

Park Body Builders are pleased to submit the following quotation

**MANUFACTURE & FIT (1) ONLY 4.6m x 2.5m x 1m 2-WAY TIPPING BODY COMPLETE WITH :**

- Floor:** 6mm 450 grade on PFC main members
- Cab Shield:** 4mm 450 grade complete with tarp tie down points and shovel holders.
- Sides:** 4mm 450 grade LH side fixed, RH side Hydraulic cylinders as per specifications
- Tail Gate:** 4mm 450 grade top/side swing inc air operated locking system and spreader chain lugs
- Tie Rails:** Down sides and tailgate
- Access Step:** Retractable type front access step to LH side
- Hoist:** 24 tonne mega hoist including end of stroke valve, safety chain and grease bank.
- Hydraulics:** Air Hot shift PTO with 80 litre oil tank, air operated tip valve
- Subframe:** Full length SHS subframe incorporating hoist, pivots.
- Safety prop:** Safety prop
- Beacons:** 2 x LED Hella beacons with cage mounted on ski bar
- Mud Guards:** All rubber guards complete with 'PBB' mudflap rubbers
- Painting:** To be sand blasted, primed, painted in 2-pack finish to match the cabin
- Underside:** Painted black to match the chassis
- Lighting:** LED Truck and high level lights to be fitted to traffic regulations including light covers
- Tool box:** tool box
- Water tank:** 60 litre water tank with soap dispenser

<b>Quoted by:</b> David Di Nella	<b>Date:</b>	<b>SUBTOTAL</b>	<b>\$ 80,500.00</b>
<b>Quotation Validity:</b> This Quotation is Valid for 30 Days Only		<b>10% GST</b>	<b>\$</b>
<b>Terms of Payment:</b> C.O.D. or AS ARRANGED		<b>TOTAL</b>	<b>\$</b>

**EXTRA ITEMS INCLUDED:**

- Extend air lines to rear with fittings
- Supply & fit PH300 & 50mm Ringfeder combo, 7 pin plug
- ABS plug
- Supply & fit air operated diverter, hydraulic to rear to suit side tipping trailer
- Black and white reflective zebra strips to tailgate
- External chain tie down points located between axles with 80mm chain hole

We trust your requirements have been interpreted correctly both technically and commercially. Should you require any additional information please do not hesitate to contact David Di Nella on 08-9378-0600, 0419299661 or [david@parkbodybuilders.com.au](mailto:david@parkbodybuilders.com.au)

**Deposit; 50% REQUIRED** **Delivery; T.B.A**  
**Payment; ON COMPLETION** **GST; 10% TO**  
**ALL PRICES**  
 All quotes valid; (fixed & firm) for 30 days and subject to Park Motor Body Builders Standard Terms and

**Conditions**

A copy of which is available on request.

**ACCEPTANCE OF QUOTE/SPECIFICATION and AUTHORITY TO PROCEED BY PURCHASER**  
**(must be signed)**

Accepted; \_\_\_\_\_ For \_\_\_\_\_ Order No;

Date: / /

(signed)

(Company Name)

---

**ITEM 8      STANDING ITEMS – CONTROLS, SYSTEMS AND PROCEDURES****8.1            Information Technology (IT) Usage Policy & Procedure****Responsible Officer**    Natalie Ness, Chief Executive Officer**Reporting Officer**      Tricia Brown, Executive Manager, Corporate Services**Attachments**            1.    Information Technology (IT) Usage Policy & Procedure [↓](#) **Voting Requirements**   Simple Majority**Disclosure of Interest** Reporting Officer: Nil

Responsible Officer: Nil

---

**OFFICER RECOMMENDATION**

That the Audit & Risk Committee recommend to Council the adoption of a new policy – Information Technology (IT) Usage Policy & Procedure

---

**IN BRIEF**

To establish guidelines on the appropriate usage of the Shire’s Information and Communication Technology systems and devices to ensure the ongoing security and integrity of the Shire’s network system.

**MATTER FOR CONSIDERATION**

Lack of documentation and guidance in respect to IT Usage expectations for employees.

**BACKGROUND**

During the Interim Audit for the year ended 30 June 2021, 3 Significant Findings in relation to the Shire’s Information Technology Environment were noted, item 2 being:

- No specific employee IT Usage policy is in place.

**STATUTORY ENVIRONMENT**

*Local Government Act 1995*

*Local Government (Administration) Regulations 1996*

*Privacy Act 1988*

**POLICY IMPLICATIONS**

Employee Code of Conduct

**FINANCIAL IMPLICATIONS**

If not addressed the findings from the audit could result in data breaches, system outages and financial loss to the Shire.

**ALIGNMENT WITH STRATEGIC PRIORITIES**

**5.4 Governance & Leadership:** Implement systems and processes that meet legislative and audit obligations

**CONSULTATION**

Nil

**RISK MANAGEMENT PRIORITIES**

This report addresses the following identified Strategic Risk Management Priorities:

Data breaches/hack of Shire information and communications technology systems impacts business continuity, results in financial or other data theft and increases liability (Elected Members, Executive and the Shire as a whole).

**RISK ASSESSMENT**

	Option 1
Financial	Low <i>The Shire’s IT Providers have controls in place to reduce the risk to the Shire’s IT infrastructure and therefore financial risk of cyber-attacks.</i>
Health	Low
Reputation	Low <i>In conjunction with the ICT Strategic Plan this policy decreases the chance of loss of information and mitigates reputations risk.</i>
Operations	Low <i>This policy in conjunctions with the ICT Strategy and IT Provider controls is designed to reduce significant impact on the Council’s ability to operate.</i>
Natural Environment	Low

Likelihood	Consequence				
	Insignificant	Minor	Moderate	Major	Critical
Rare	LOW Accept the risk Routine management	LOW Accept the risk Routine management	LOW Accept the risk Routine management	MEDIUM Specific responsibility and treatment	HIGH Quarterly senior management review
Unlikely	LOW Accept the risk Routine management	LOW Accept the risk Routine management	MEDIUM Specific responsibility and treatment	MEDIUM Specific responsibility and treatment	HIGH Quarterly senior management review
Possible	LOW Accept the risk Routine management	MEDIUM Specific responsibility and treatment	MEDIUM Specific responsibility and treatment	HIGH Quarterly senior management review	HIGH Quarterly senior management review
Likely	MEDIUM Specific responsibility and treatment	MEDIUM Specific responsibility and treatment	HIGH Quarterly senior management review	HIGH Quarterly senior management review	EXTREME Monthly senior management review
Almost certain	MEDIUM Specific responsibility and treatment	MEDIUM Specific responsibility and treatment	HIGH Quarterly senior management review	EXTREME Monthly senior management review	EXTREME Monthly senior management review

**COMMENT**

Protection of the Shire’s IT infrastructure requires a multi-faceted approach from Council, Staff and our external IT Providers to maintain network integrity.



## INFORMATION TECHNOLOGY (IT) USAGE POLICY & PROCEDURE

### PURPOSE

The purpose of this Shire of Quairading Information Technology Acceptable Use Policy and Procedure is to:

- Clearly identify the parameters when using Shire of Quairading's information & communication technologies
- Outline the process for using Shire of Quairading's information & communication technologies
- Protect the interests, intellectual property, and IT assets of the Shire of Quairading.

### OBJECTIVE

This Information Technology Acceptable Use Policy applies to Councillors and all Council Employees of the Shire of Quairading (SOQ) who use information and communication technologies for or on behalf SOQ. This document provides direction on the acceptable use of SOQ's information and communication technologies, and personal use of QSC's information and communication technologies.

### DEFINED TERMS

**CEO** - The person appointed to the position of Chief Executive Officer under the Local Government Act 2009, and anyone acting in that position.

**Council** - Shire of Quairading Council

**Executive Manager** - A person appointed in an Executive level position

**Employee** - Includes any person employed by Council and persons providing services to or on behalf of Council, including Elected members

**Email** - A service that enables people to exchange document or material in an electronic format

**Hack** - To gain access into another's computer system or files by illegal or unauthorised means

**Information Technology (IT)** - An umbrella term covering websites, technology, applications, or tools that enable an exchange of dialogue between organisations, communities and individuals. IT may include but is not limited to:

- Computers - desktop and laptops
- Mobile devices - phones and tablets
- Internet - corporate and public, physical and wireless

- Software – email, content creation

**Internet** – A global research, information and communication network providing services such as access to information, file transfer and electronic mail  
**Material** – Includes data, information, text, graphics, animations, speech, videos, photos, maps and music or other sounds, accessible electronically, including any combination or selection of any of these  
**Standard Operating Environment (SOE)** – refers to the specific combination of computer hardware and software configuration on Council computers.

**Material** – Includes data, information, text, graphics, animations, speech, videos, photos, maps and music or other sounds, accessible electronically, including any combination or selection of any of these

**Standard Operating Environment (SOE)** – refers to the specific combination of computer hardware and software configuration on Council computers.

#### **POLICY STATEMENT**

The Shire of Quairading is conscious of the need to handle Council information in a way that promotes and maintains the public's trust and confidence in the integrity of Council whilst maintaining privacy and confidentiality under the corresponding legislative Act's.

Council holds information about a range of matters relating to Council business and information relating to private individuals and commercial entities. Council acknowledges that to minimise risks to the Council and residents, Council must manage all IT devices in a way to preserve the privacy and confidentiality of information held by Council to the fullest extent possible.

#### **PROCEDURE**

##### **Acceptable Use**

The Council information technology (IT) infrastructure and services are primarily for Council business use and must be used in accordance with legislative requirements and the guidelines set out in this Policy.

##### **SOE Access**

Employees will only be granted access to Council's operating environment once a New User Access Request Form has been completed through our IT Providers.

##### **Personal Usage**

Employees may be permitted to use Council IT equipment and infrastructure for private purposes – only where such use is open, accountable, and transparent. Private use must always be appropriate and lawful and not interfere with employee's capacity or ability to perform their respective duties.

##### **Passwords**

Passwords are an employee's electronic authorisation used to gain access to Councils IT systems. Employees are responsible for the security and regular changing of their password(s).

Passwords are created by our IT Providers at the time access to the SOQ's (IT) infrastructure is granted. Passwords are required to be regularly changed and adhere to specific guidelines created by our IT Providers.

Employees are required to take reasonable precaution to ensure that their password is not known by any other party, this includes not writing the password down in an easily accessible location. Employees must not disclose their password(s) to anyone however employees may be required to disclose their password to an Executive or IT staff, in this instance the employee may request that their password be changed before disclosing.

### Identity

No email or other electronic communication may be sent for or on behalf of Council which conceals or attempts to conceal the identity of the sender. All Council email correspondence is required to include the standard Council email signature, which must include the following:

- Employee Name
- Employee Title/Position
- Employee email address
- Council Emblem & name
- Council primary contact number (no direct extensions to be advertised)
- Council mobile number (if employee has been issued a mobile phone)
- Council Postal address
- Links to Council websites (Corporate & Tourism)

The only exception is where it is intended to keep the identity of the sender anonymous, such as position or purpose related mailboxes (i.e. HR, Jobs, Info, Tenders), which may omit an Employees name.

### Email Usage

Council email access is provided to employees on an "as required" basis. Council provided email is strictly to be used for Council business purposes only.

Employees must exercise care and discretion with electronic communication such as tenders, contracts, confidential agendas, minutes, and reports.

Email messages are perceived to be instant in nature and instantly disposed of, however all emails sent and received from Council email are backed up and stored indefinitely, regardless of any accidental or deliberate deletion.

Improper statements can give rise to liability, personally and for Council. Employees must operate on the assumption that messages may be sent to, forwarded to, transmitted or printed by someone other than the intended recipient.

Employees must be aware that email messages, even if expressed to be confidential, may be disclosed in legal proceedings, Freedom of Information requests, or as required by law.

Employees should follow 'best practice' when using Council email, so as not to cause Council disrepute. Best practice examples include:

- Subject line should be clear and concise and not contain the body of the email
- Contents of the email should be lawful and free of error
- All sent emails must contain the standard Council signature

### Security

To increase data security, Council computers are configured to lock access after a period of inactivity. After this time employees will be required to re-enter their passwords to re-gain access. Employees must not attempt to circumvent this security function.

Employees are required to lock their computers when leaving their desk for extended periods of time. Employees found to consistently leave their computer unsecured may be subject to disciplinary actions.

Employees must not attempt to gain access to another employee's user account, whether by knowing or guessing another employee's password or by other methods. Employees found to attempt to hack Council IT systems may be subject to disciplinary action.

Unknown USB storage devices are a high risk to Council data security. Employees must not attach unknown USB devices to any Council IT systems, this includes but is not limited to, USB storage devices containing files or material required to be printed by a member of the public, and personal Employee USB storage devices.

### Remote Access

Employees may be authorised to access Councils network remotely. Remote access may be granted on an "as required" basis only when required to work away, under authorisation from the CEO or appropriate department Executive.

Employees authorised for remote access shall have a secure Council laptop to be used for Council business only. Employees should not store data on the laptop provided, and should assume that any data stored will be removed upon return.

The following employee positions may be issued with a Council administered laptop for the duration of their employment:

- CEO, Executives and Elected Members
- Staff with the executive's approval

Laptops issued are to be used for Council business only. Under no circumstances is an employee to install software, modify configuration settings, or provide use of the issued laptop to anyone but Council IT staff. An employee issued with a Council laptop may be held responsible for any unlawful or unauthorised activity conducted on a Council issued laptop.

Exceptions may be made for companies which have entered into an agreement with Council for managed services that require frequent remote access. These companies shall be liable for any damage or data loss caused as a result of their remote access.

Employees found to be accessing Council IT systems remotely from an unauthorised computer or device may be subject to disciplinary action.

Under no circumstances are employees to grant remote access to a Council IT System to any persons via TeamViewer or any other method unless authorised to do so by Council IT staff. Employees found to allow unauthorised remote access to Council's network may be subject to disciplinary actions.

#### Document Management

Council utilise Altus Content as a document management system. Employees required to use Council computers to perform their duties will be granted a "user workspace" inside Altus Content.

Employees with access to Altus Content are required to store all Council documents and Council business related emails in Altus Content.

#### Data Storage

Employees will be granted access to Council data resources via mapped network drives on an "as required" basis. Authorisation to access a mapped network drive is to be granted or denied via the IT providers Change to Employee Access Request Form, with approval from the appropriate Executive.

Employees will be granted access to the 'T' drive on a work requirements basis. This drive is to be used for Council business only. Employees must not store unlawful content on Council IT systems. Council IT staff may monitor data stored on Council IT systems and infrastructure, and report findings to the CEO.

#### Hardware Care

Employees must not interfere with the physical configuration (i.e. placement, cabling, etc.) of Council IT systems including but not limited to, computers, printers, desk phones, power, and data. Any required configuration changes are to be authorised by IT staff/executive staff prior to any changes being made

Employees are responsible for the care of their Council IT equipment, and may be held accountable for any physical damages that may occur. Employees must report any physical damage to Council IT equipment to IT staff immediately.

Employees are required to shut down programmes and turn off their computers at the end of each workday, unless otherwise directed by Council IT staff/Executive staff for the purpose of maintenance.

#### Mobile Devices

Dependant on positional requirements, employees may be issued with a mobile device (i.e. Mobile phone, tablet) to assist with performing their duties. The type of mobile device issued will depend on the requirements of the employee's position.

The employee roles that may be issued a mobile device are:

- CEO, Executives
- Managers/Supervisors

- Officers that are directed to carry a device as part of their role Employees are responsible for the care of the mobile device issued and may be held accountable for loss or damages caused. The mobile device must be carried by the Employee at all times during hours of employment and must not be forwarded or redirected to a personal mobile device.

Employees are not permitted to use a Council issued mobile device for personal use.

Employees found to use a Council issued mobile device for personal use may be held accountable for any excess charges relating to that personal use. If an Employee incurs excess usage charges on a Council mobile device whilst on leave or otherwise not performing duties related to Council business, that employee may be held accountable for those excess charges.

Upon an Employees termination, all issued IT devices must be returned to Council.

#### **IP Telephones**

Dependant on positional requirements, Employees may have a Council desk phone configured in their workspace. These desk phones are to be used for Council business only.

Employees should limit publicising their direct dial extension numbers and should direct contact to Council's primary contact number when possible.

Employees are responsible for the care of their desk phones, and any damages or faults must be reported to IT staff/Executive staff.

#### **BYOD – Bring your own device**

Council does not support the use of BYOD laptops.

Personal laptops and mobile devices may only be connected to Council's IT infrastructure under the authorisation of Council IT staff or CEO/Executives.

#### **Internet Use**

Council internet is intended to be used primarily for Council business, though employees are permitted to access the internet for personal use where that personal use is lawful and does not impact the employee's ability or capacity to perform their duties.

Council internet usage is monitored by IT providers to determine both the appropriateness of the content being viewed, as well as the impact the usage may have on Council operation due to data and bandwidth usage. Council IT providers may report on employee internet usage to the CEO/Executive if required.

Council have content filtering active on Council's internet service, used primarily to block malicious, inappropriate, or unlawful content. If an employee cannot gain access to a website that is required to perform their duties, due to content filtering, they may contact Council IT staff/Executives to request that the restriction be removed.

#### **Wi-Fi Access**

Council operate and maintain two separate wireless networks in varying Council buildings. One free for public usage, the other is a corporate wireless network that connects directly to Councils IT systems and infrastructure for staff.

Employees are free to use the public wireless network in a lawful manner, provided it does not impact their ability or capacity to perform their duties.

Councils corporate wireless network is secured by a wireless key and is to be accessed by Council employees from authorised devices only. Authorisation can be granted to an employee using the online portal, provided the employee has reasonable requirement to use the wireless network and has been issued a Council mobile device.

Visiting guests of Council that require unrestricted wireless internet may be granted access to Councils hidden guest wireless network. If a guest requires wireless internet access, a Council employee may request the access details from Council's IT provider.

### Software Configuration

Under Councils SOE, all Council IT equipment should have the same software packages installed. Exceptions may be made to the Council SOE where specific software is required for specific positions, these exceptions will be made at Executive staff discretion after assessing the requirements.

Employees must not attempt to modify or install software on any Council IT system. If software not currently part of the SOE is required, Employees may contact Council Executive staff to request that the software be installed, Council Executive staff will review the request and approve or deny the request if appropriate and compatible with Councils IT systems.

Employees must not attempt to alter the configuration of any Council IT systems. If configuration changes are required, employees may request the change by contacting Council Executive staff.

### Malicious Software Protection

Council IT systems are protected from malicious software protection through the implementation of a number of layers of protection:

- Incoming & outgoing email filtering and inspection
- Internet content filtering & firewall
- Local antivirus/malware software

While Council's protection methods are effective in preventing most malicious software infections, employees must be cautious when opening emails and files from unknown or suspicious sources. Employees are encouraged to contact IT/Executive staff when they suspect a possible threat of infection.

### Printing

Employees are encouraged to assess requirements before printing large or high-volume documents. Where possible, employees should print in greyscale to the high-volume photocopiers located in each Council building.

Employees should refrain from using smaller desktop printers unless necessary. Employees are responsible for replacing and ordering consumables for printers using the contact details located on each printer, Council IT staff may assist when required.

Visitors and members of the public that request to print material must be directed to email the file to a Council employee for printing. This ensures the file is inspected and scanned for malicious code by Council's email server.

Visitors and members of the public that request to print material but do not have the ability to email the file to a Council employee, must be directed to print from the publicly accessible computers available for use at the Quairading CRC. Under no circumstances should a Council employee attach an unknown USB storage device to Council IT Systems for the purpose of printing.

#### **IT Support**

When an issue with Council IT systems or infrastructure is identified, an employee is to advise IT staff and submit a support ticket to the IT Providers or the Software Providers dependant on the operating system issue. If an Employee is unable to submit a support ticket due to the nature of the issue, they may contact IT staff directly.

#### **CONFIDENTIALITY**

Employees should perform their duties under the assumption that all data stored on Council IT systems is accessible by IT Employees and the CEO upon request and may be reported on if required.

Employees must be aware that data and email messages, even if expressed to be confidential, may be disclosed in legal proceedings, Freedom of Information requests, or as required by law.

#### **COPYRIGHT**

The copyright over artistic, literary, dramatic or musical work authored by SOQ employees whilst carrying out work duties is owned by the SOQ as per the Copyright Act 1968 (s35) unless by prior arrangement.

Under no circumstances is a Council employee to replicate unauthorised copies of Council data, information, or Intellectual Property for purposes other than Council business. Employees found to be doing so may be subject to disciplinary action.

Employees are required to adhere to the requirements of copyright legislation. Intellectual property rights apply to most material on the internet, including text, graphics, and sound. Employees must not assume they can reproduce, print, transmit, or download material to which they have access. Usage of any material should comply with copyright legislation, as any material reproduce outside permitted uses or without the permission of the owner may result in litigation action against Council.

#### **UNLAWFUL ACTIVITY**

Employees must not conduct or be party to any unlawful activity while using or through the use of Council IT systems. Any unlawful activity found to occur will be reported directly to the CEO and appropriate law enforcement agencies.

#### **COMMUNICATION**

- Councillors and all Council employees will have access to this policy.
- Councillors and all Council employees will be provided with opportunities to be involved in the review of this policy.



- Council employees will be provided with information from this policy at the time of employment and orientation.
- Changes/amendments made to this Policy document will be communicated to all Councillors and Council employees.

**ENFORCEMENT**

Non-compliance with this policy could place Council in breach of both the Local Government Act 2009 and/or the Information Privacy Act 2009. It is important to note that non-compliance with this policy/procedure by an individual could lead to personal liability and/or criminal prosecution.

The failure of any Council employee to comply with this policy in its entirety may lead to:

- Refresher or further training,
- Performance management, or
- Modification or termination of employment.

**STATUTORY ENVIRONMENT**

Local Government Act 2009

Copyright Act 1968

Right to Information Act 2009

Information Privacy Act 2009

Crime & Corruption Act 2001

Invasion of Privacy Act 1971

**CEO DISCRETION**

Where applicable, the CEO can apply their discretion as to the enforcement of the requirements outlined in this policy and any requests for variations to this policy.

**REVIEW OF POLICY**

This policy remains in force until amended or repealed by resolution of Council. This document will be reviewed biannually or as required.

Record of Policy Review						
Version	Author	Council Adoption	Resolution	Reason for Review	Review Date	CEO Signature
01	Tricia Brown			New Policy		

**8.2 Request to Increase Credit Card Limits**

<b>Responsible Officer</b>	Natalie Ness, Chief Executive Officer
<b>Reporting Officer</b>	Tricia Brown, Executive Manager, Corporate Services
<b>Attachments</b>	Nil
<b>Voting Requirements</b>	Simple Majority
<b>Disclosure of Interest</b>	Reporting Officer: Nil Responsible Officer: Nil

---

**OFFICER RECOMMENDATION**

That the Audit & Risk Committee recommend to Council that; Council approve the increase in Credit Card Limits as per the below;

1. Chief Executive Officer – Limit \$5,000
  2. Executive Manager Works & Services – Limit \$5,000
  3. Executive Manager Corporate Services – Limit \$2,000
  4. Community Emergency Services Manager – Limit \$5,000
- 

**IN BRIEF**

Council credit cards are issued to all Executive Staff and the Chief Executive Officer to allow purchases to be made on behalf of the Council that cannot ordinarily or easily be purchased via invoice/EFT or are urgent in nature.

**MATTER FOR CONSIDERATION**

The use of corporate credit cards is not specifically mentioned in the Local Government Act 1995. However, the impacts of the use and control of corporate credit cards are related to the following sections of the Local Government Act 1995:

1. Section 2.7(2)(a) and (b) requires the Council to oversee the allocation of the local government's finances and resources and determine the local government's policies; and
2. Section 6.5(a) requires the CEO to ensure that there are kept, in accordance with regulations, proper accounts and records of the transactions and affairs of the local government.

Local Government (Financial Management) Regulations 1996 Section 11(1)(a) requires local governments to develop procedures for the authorisation of, and the payment of, accounts to ensure that there is effective security for, and properly authorised use of cheques, credit cards, computer encryption devices and passwords, purchasing cards and any other devices or methods by which goods, services, money, or other benefits may be obtained.

**BACKGROUND**

Council has predominately issued the Chief Executive Officer with a limit of \$5,000 and \$1,000 for Executive Staff, however increasingly the limit for Executive Staff is proving to be inadequate.

The CESM credit card has reached its limit 4 times in the past 6 months leaving the Manager having to use personal funds in order to carry out purchases pertinent to the role. With the fire season approaching and the potential for increased emergency expenditure an increase in the credit card limit to \$5,000 will allow funds to be available when needed for emergency welfare and incident related costs.

The EMWS has also noticed delays in being able to purchase items due to the internal processes of Creditor Management. An increase in the limit to \$5,000 would significantly reduce the delays and allow increased efficiency for those items required to be purchased outside of the normal invoicing structure.

**STATUTORY ENVIRONMENT**

*Local Government Act 1995*

*Local Government (Administration) Regulations 1996*

**POLICY IMPLICATIONS**

Corporate Credit Card Policy

Payments from the municipal or trust funds

Purchasing Policy

**FINANCIAL IMPLICATIONS**

There are no financial implications that have been identified as a result of this report. Expenditure on credit cards still requires to coincide with the approved budget and the Shire's purchasing policy.

**ALIGNMENT WITH STRATEGIC PRIORITIES**

**5.4 Governance & Leadership:** Implement systems and processes that meet legislative and audit obligations

**CONSULTATION**

Nil

**RISK MANAGEMENT PRIORITIES**

This report addresses the following identified Strategic Risk Management Priorities:

Financial misconduct by (a) a Shire employee, and (b) an executive/office holder results in financial, legal and/or reputational damage.

**RISK ASSESSMENT**

	Option 1
Financial	Low <i>Executive Management are still required to only purchase according to their allocated budget.</i>
Health	Low
Reputation	Low <i>Staff are all required to adhere to the Credit Card Policy and are aware of the consequences of misuse in representation of Council</i>
Operations	Low <i>Can significantly reduce delays in processing for urgent items</i>
Natural Environment	Low

	Consequence				
Likelihood	Insignificant	Minor	Moderate	Major	Critical
Rare	LOW Accept the risk Routine management	LOW Accept the risk Routine management	LOW Accept the risk Routine management	MEDIUM Specific responsibility and treatment	HIGH Quarterly senior management review
Unlikely	LOW Accept the risk Routine management	LOW Accept the risk Routine management	MEDIUM Specific responsibility and treatment	MEDIUM Specific responsibility and treatment	HIGH Quarterly senior management review
Possible	LOW Accept the risk Routine management	MEDIUM Specific responsibility and treatment	MEDIUM Specific responsibility and treatment	HIGH Quarterly senior management review	HIGH Quarterly senior management review
Likely	MEDIUM Specific responsibility and treatment	MEDIUM Specific responsibility and treatment	HIGH Quarterly senior management review	HIGH Quarterly senior management review	EXTREME Monthly senior management review
Almost certain	MEDIUM Specific responsibility and treatment	MEDIUM Specific responsibility and treatment	HIGH Quarterly senior management review	EXTREME Monthly senior management review	EXTREME Monthly senior management review

**COMMENT**

Staff are still required to keep all tax invoices pertinent to the purchases made and therefore complies with our Records Management Policy.

All staff are required to sign the Corporate Credit Card Agreement – Annexure B acknowledging and accepting the conditions of the Shire of Quairading Corporate Credit Card Policy.

All credit card transactions are reported to Council for transparency with the Audit & Risk Chairperson personally reviewing those transactions for accuracy and legitimacy.

**8.3 Response to Minister following adoption of ICT Strategic Plan 2022-2025****Responsible Officer** Natalie Ness, Chief Executive Officer**Reporting Officer** Tricia Brown, Executive Manager, Corporate Services**Attachments** 1. (i) 2021/2022 Annual Audit - Reporting of Significant Matters [↓](#) **Voting Requirements** Simple Majority**Disclosure of Interest** Reporting Officer: Nil

Responsible Officer: Nil

On 29 March 2023, the Auditor General tabled a report in Parliament on the Information Systems Audit – Local Government 2021-2022. In this report, the Auditor General recommended that under section 7.12A of the Local Government Act 1995 (the Act), that local governments identified as having significant information system issues:

- Prepare an action plan addressing significant matters relevant to their entity

We ask that the Audit & Risk committee note the Shire's response to the Minister for Local Government following the adoption of the ICT Strategic Plan 2022-2025, Resolution: OCM 099-23/24.



Your Ref: Information Systems Audit – Local Government 2021-22

Our Ref: Audit 2021-2022

7<sup>th</sup> November 2023

10 Jennaberring Road  
Quairading WA 6383  
PO Box 38, Quairading WA 6383  
T: (08) 9645 2400  
F: (08) 9645 1126  
E: shire@quairading.wa.gov.au

Hon David Michael MLA  
Minister for Housing and Local Government  
7th Floor, Dumas House,  
2 Havelock Street,  
WEST PERTH WA 6005  
(Via: [Minister.Michael@dpc.wa.gov.au](mailto:Minister.Michael@dpc.wa.gov.au))

Dear Hon Minister,

#### **2021/22 Annual Audit – Reporting of Significant Matters**

As required by Section 7.12A of the *Local Government Act 1995* (LGA) we wish to report to you the significant matter that has been tabled in Parliament on the Information Systems Audit – Local Government 2021-2022 which identified the Shire of Quairading as having significant system issues:

- Is to prepare an action plan addressing significant matters relevant to their entity
- For submissions to the Minister for Local Government (the Minister) be made within 3 months of the report being tabled.

#### **Management comment:**

1. The Shire previously responded to the Minister on 6<sup>th</sup> September in relation to Significant Findings in the 2021-2022 Audit specific to the Shire of Quairading.
2. Management acknowledges the recommendation to prepare an action plan addressing significant matters relevant to their entity.
3. The Shire and its service provider have formally written an ICT Strategic Plan 2022-2025 which provides direction for addressing both short and long term requirements for cost-effective, practical technological Solutions. This outlines the current and future budget costings and expectations of the technical environment today and going forward. This document provides for Industry 'Best Practice' in various performance areas, e.g., Antivirus, Domain and Internet Gateways.

The ICT Strategic Plan 2022-2025 was adopted by Council at the Ordinary Council Meeting 26<sup>th</sup> October 2023, Resolution: OCM 099-23/24. This will be the Shire's informing document in relation to ICT Management and will also drive our Disaster Recovery Plan. Our Disaster Recovery Plan is expected to be reviewed once our ICT

Strategic Plan was adopted and dedicated testing of the Disaster Recovery Plan will be conducted.

4. A copy of the adopted 2022-2025 ICT Strategic Plan is attached for your records.
5. Officers of the Shire of Quairading will be submitting an "IT Usage Policy" to Council at the November 14<sup>th</sup> Audit & Risk Committee meeting with the intention to have this adopted at the November 30<sup>th</sup> OCM.

Should you require further information or clarification on the above, please contact me via email, [natalie.ness@quairading.wa.gov.au](mailto:natalie.ness@quairading.wa.gov.au) call 08 9645 2400.

Yours sincerely,

*Natalie Ness*

**Natalie Ness**  
CHIEF EXECUTIVE OFFICER



---

**ITEM 9 STANDING ITEMS – RISK MANAGEMENT REPORTS AND ISSUES****9.1 Report on excess annual leave and long service leave entitlements**

<b>Responsible Officer</b>	Natalie Ness, Chief Executive Officer
<b>Reporting Officer</b>	Tricia Brown, Executive Manager, Corporate Services
<b>Attachments</b>	Nil
<b>Voting Requirements</b>	Simple Majority
<b>Disclosure of Interest</b>	Reporting Officer: Responsible Officer:

---

**OFFICER RECOMMENDATION**

That the Audit & Risk Committee recommends to Council that Council receive the report on the Shire's leave liabilities.

---

**IN BRIEF**

- Since 2017, Council has requested that excess annual leave and long service leave be reported to the Audit and Risk Committee.
- Not taking a reasonable amount of annual leave or long service leave may pose a threat to the health and safety of employees and represent a significant financial liability for the Shire, therefore there are steps in place to ensure that leave balances are monitored and are at appropriate levels.
- Employee entitlement movements during the year are due to many reasons, such as, leave taken during the period, increased accrued leave balances, increases in remuneration rates and changes in the underlying staff with leave balances transferred to and from the Shire.

**MATTER FOR CONSIDERATION**

Receipt of the report on excess annual leave and long service leave entitlements and leave liabilities.

**BACKGROUND**

Since 2017, Council has requested that excess annual leave and long service leave be reported to the Audit and Risk Committee.

The current Leave Management Policy defines "excess leave" as when the employee has accrued more than eight weeks paid annual leave and provides management with direction to effectively manage the annual and long service leave entitlements of employees.

The Shire encourages employees to take leave by reinforcing the positive benefits of taking leave when it becomes due. Sometimes there are circumstances that prevent leave being able to be taken, such as staff shortages, outside influences and work demands.

There will be movements in employee entitlements throughout the year. Balances will increase naturally as employees accrue leave entitlements and decrease when employees take leave accrued. This natural fluctuation is monitored by management and through this report to ensure any excess is managed appropriately.

### **STATUTORY ENVIRONMENT**

*Fair Work Act 2009*

*Local Government Act 1995*

*Local Government (Financial Management) Regulations 1996*

*Work Health & Safety Act 2020*

### **POLICY IMPLICATIONS**

Leave Management Policy

### **FINANCIAL IMPLICATIONS**

The Employee Entitlements (Annual and Long Service Leave) reserve fund cash balance as of 30<sup>th</sup> June 2023 is \$171,302.47.

The annual budget treats current leave as accruals.

The current liability for both types of leave (if all claimed on 28 February 2023) is calculated at \$124,660.54.

There is currently surplus in the reserve account in comparison to the liability accrued of \$46,641.93. This has been reviewed through the finalisation of the 22/23 annual financial report, with a recommendation to keep the funds in surplus in this reserve for future leave liabilities as some employees' long service leave entitlements will start to accrue as they meet the legislative threshold.

### **ALIGNMENT WITH STRATEGIC PRIORITIES**

- 5.3 Governance & Leadership:** Provide informed and transparent decision making that, meets our legal obligations, and the needs of our diverse community
- 5.4 Governance & Leadership:** Implement systems and processes that meet legislative and audit obligations

### **CONSULTATION**

Nil.

### **RISK MANAGEMENT PRIORITIES**

This report addresses the following identified Strategic Risk Management Priorities:

Non-compliance with work health and safety legislation increases the risk and potential liability to the public, staff and Councillors.

Work health and safety legislation increases liability of Councillors and Executive (personal wealth and assets) in the management of Bushfire and Volunteer Fire and Rescue Services Brigades.

Low employee retention increases recruitment costs, decreases employee morale and decreases Shire reputation.

**RISK ASSESSMENT**

Option 1	
Financial	Low <i>Financial exposure and therefore risk escalation occurs if leave accruals are not monitored and managed. Adequate reserve balances reduce the risk of financial exposure.</i>
Health	Low
Reputation	Low
Operations	Low <i>Impact to operations where employees with excess leave are requested to take leave. This can be mitigated by agreement of mutually acceptable timeframes for taking leave that are not during heavy workload times.</i>
Natural Environment	Low

Likelihood	Consequence				
	Insignificant	Minor	Moderate	Major	Critical
Rare	LOW Accept the risk Routine management	LOW Accept the risk Routine management	LOW Accept the risk Routine management	MEDIUM Specific responsibility and treatment	HIGH Quarterly senior management review
Unlikely	LOW Accept the risk Routine management	LOW Accept the risk Routine management	MEDIUM Specific responsibility and treatment	MEDIUM Specific responsibility and treatment	HIGH Quarterly senior management review
Possible	LOW Accept the risk Routine management	MEDIUM Specific responsibility and treatment	MEDIUM Specific responsibility and treatment	HIGH Quarterly senior management review	HIGH Quarterly senior management review
Likely	MEDIUM Specific responsibility and treatment	MEDIUM Specific responsibility and treatment	HIGH Quarterly senior management review	HIGH Quarterly senior management review	EXTREME Monthly senior management review
Almost certain	MEDIUM Specific responsibility and treatment	MEDIUM Specific responsibility and treatment	HIGH Quarterly senior management review	EXTREME Monthly senior management review	EXTREME Monthly senior management review

**COMMENT**

This report has been prepared to inform the Audit and Risk Committee of the current leave liabilities and of any employees who have excess leave and the steps taken to reduce these liabilities.

As of November 2023, there has been moderate change overall to both the annual leave and long service leave liabilities, this is due to employee movement and length of service since the January 2023 Report.

Two employees with annual leave balances have separated during this time, being paid out their accrued entitlements upon termination. There have been eight new employees onboarded who have started to accrue leave entitlements.

There have been some changes in entitlement accruals due to pay increases from internal movement (changes in positions). This impact is minimal.

**Annual Leave:** Two employees who had annual leave accruals have separated, removing their annual leave entitlement on termination. A moderate amount was paid out in annual leave, reducing the leave liability moderately.

We have recruited eight (8) new employees who have all accrued minimal hours.

There are currently two employees with excess annual leave. One of the employees regularly has high excess leave, although the employee has recently taken leave to reduce the liability. Both employees' Executive Manager has been advised and will encourage the staff members to reduce their balance to an acceptable level.

There has been a decrease of 22% (dollar value) in the annual leave liability since January 2023.

**Long Service Leave:**

Two employees long service leave accrual amount (hours entitled) has increased. Long Service Leave is now due for these two employees. Executive Managers are working with the employees to determine suitable times for the leave to be taken.

There has been an increase of 69% (dollar value) in the long service leave liability since January 2023.

The following table and graphs show the fluctuations in the accrued hours and dollar values of both annual leave and long service leave over the period of January 2023 to 28 October 2023.

	LSL Hours	LSL \$	A/L Hours	A/L \$
January 23	380	16,568	2,545	118,286
February 23	380	16,568	2,488	116,018
March 23	380	16,568	2,508	117,305
April 23	380	16,568	2,371	107,734
May 23	399	10,158	2,579	118,058
June 23	790	26,861	2,386	98,119
July 23	790	26,861	2,386	98,119
August 23	790	28,117	2350	100,185
September 23	790	28,117	2354	101,747
October 23	790	28,117	2276	91,401
November 23				

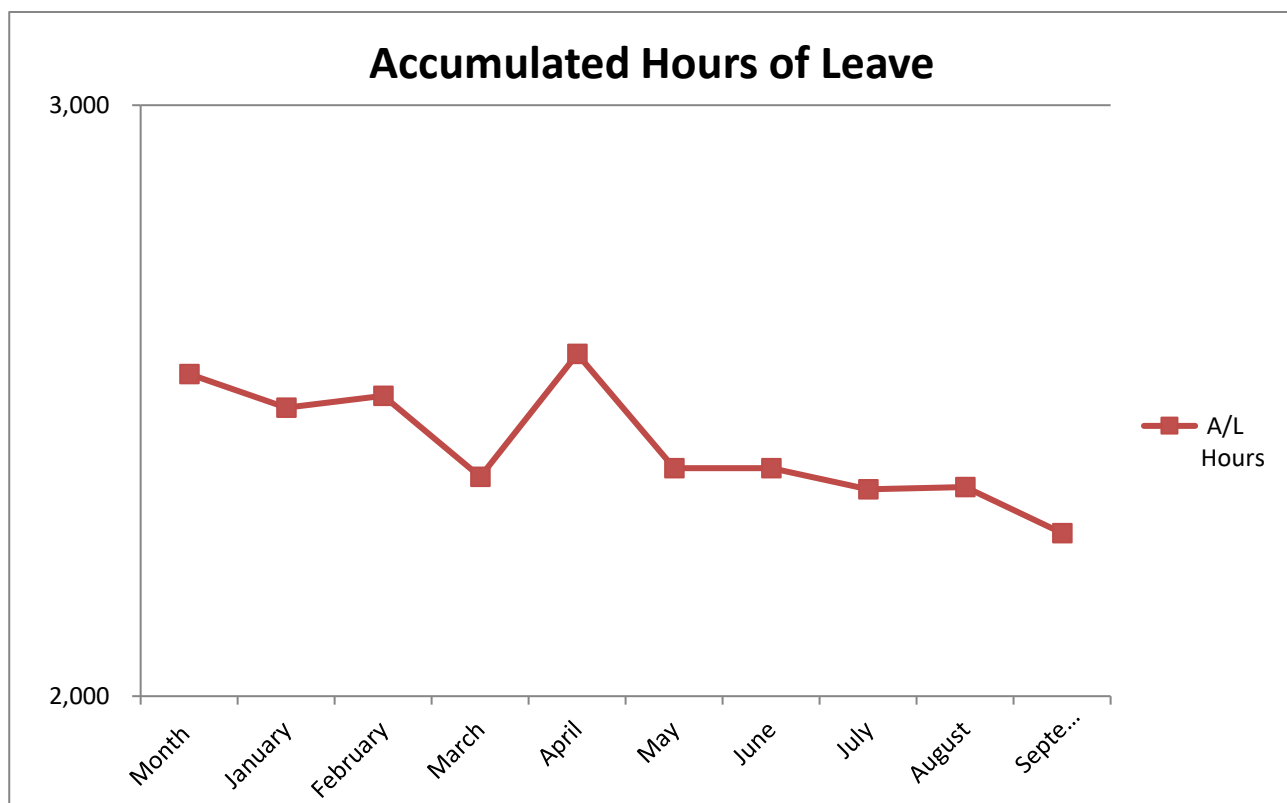
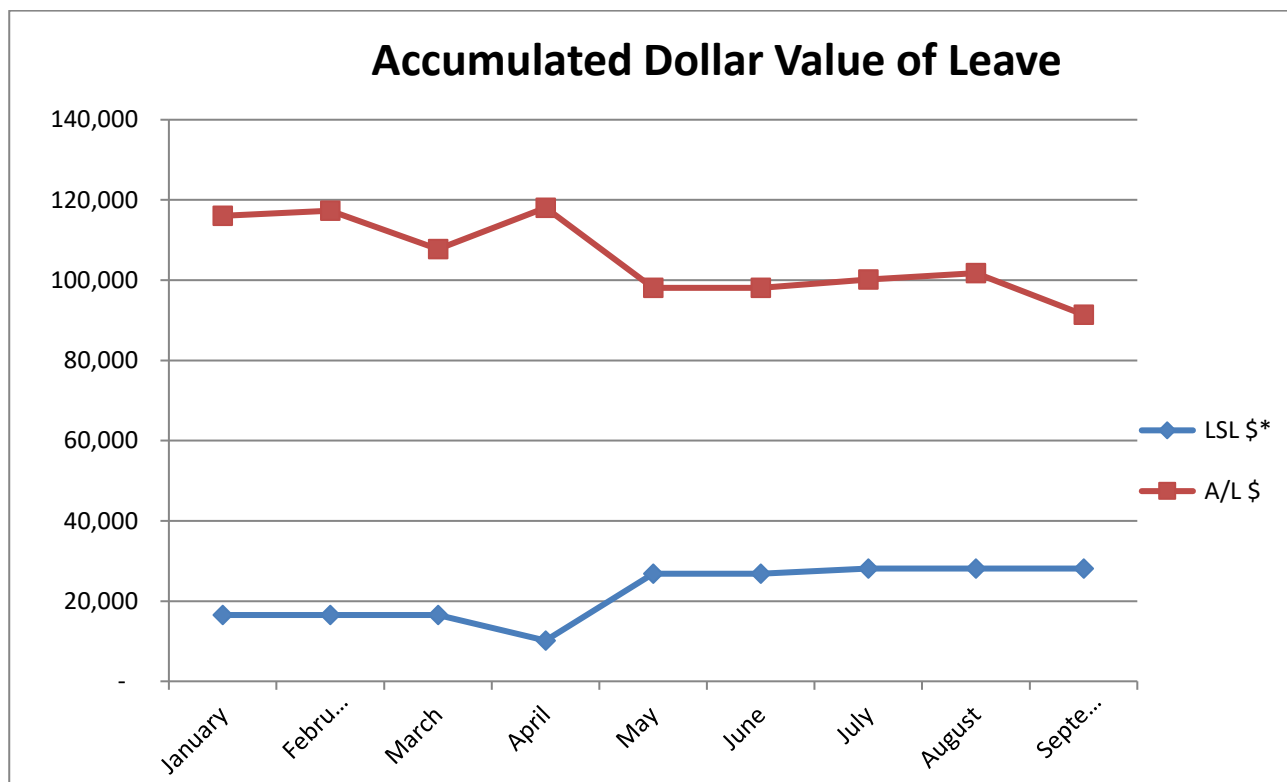

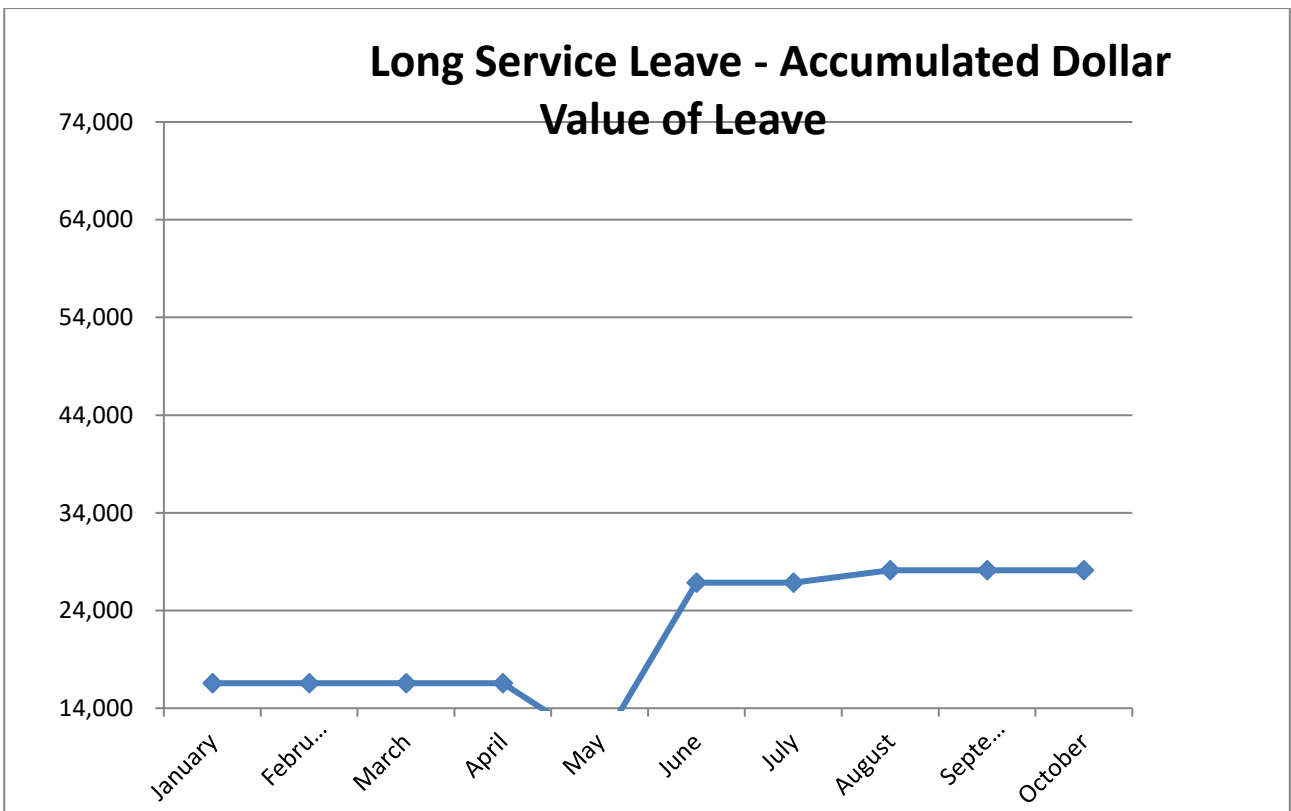
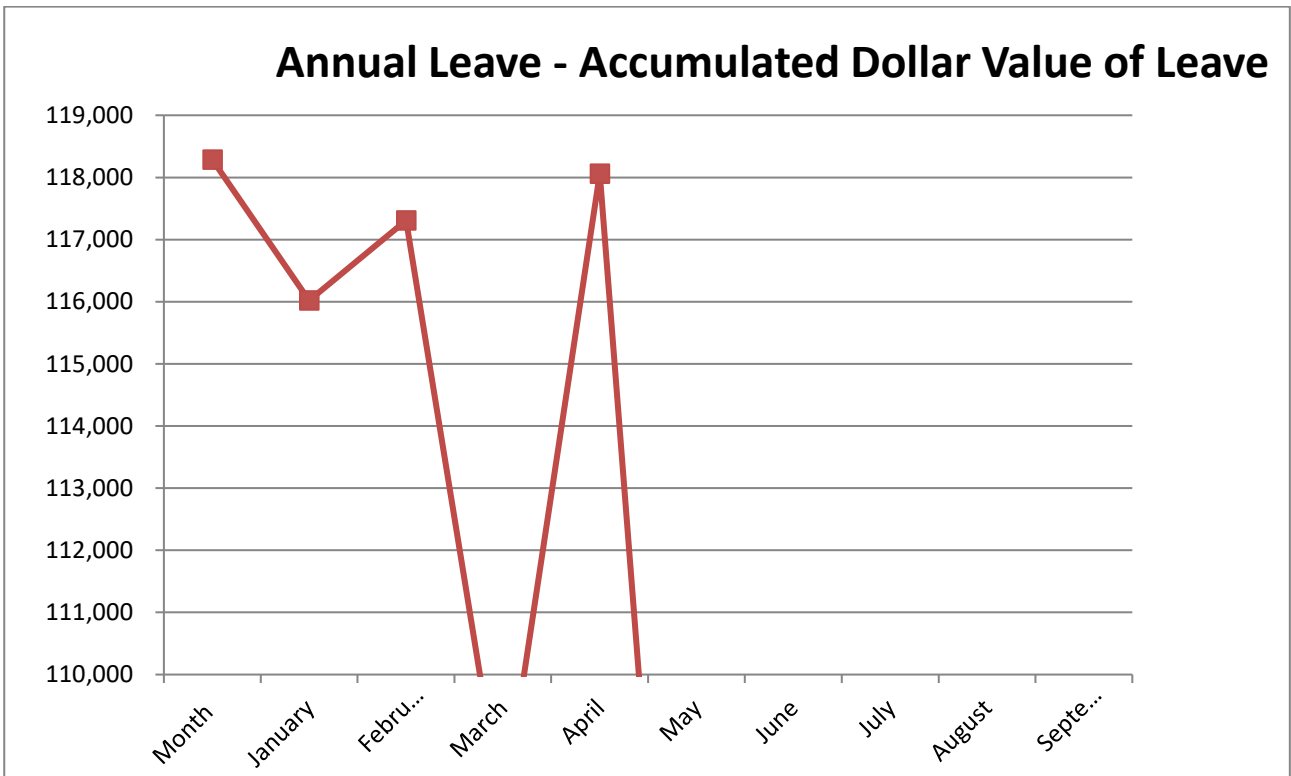

**ITEM 10    EMERGING ISSUES/LATE ITEMS**

**ITEM 11      NEXT MEETING DATE**

The next Audit & Risk Committee Meeting will be scheduled by Council at its OCM on 30 November 2023.

**ITEM 12      CLOSURE**

There being no further business, the Chairperson closed the Meeting at \_\_\_\_\_ pm.